

TECHNICAL TRAINING SOLUTIONS FOR INDUSTRIAL AUTOMATION, ELECTRICAL ENGINEERING AND ROBOTICS

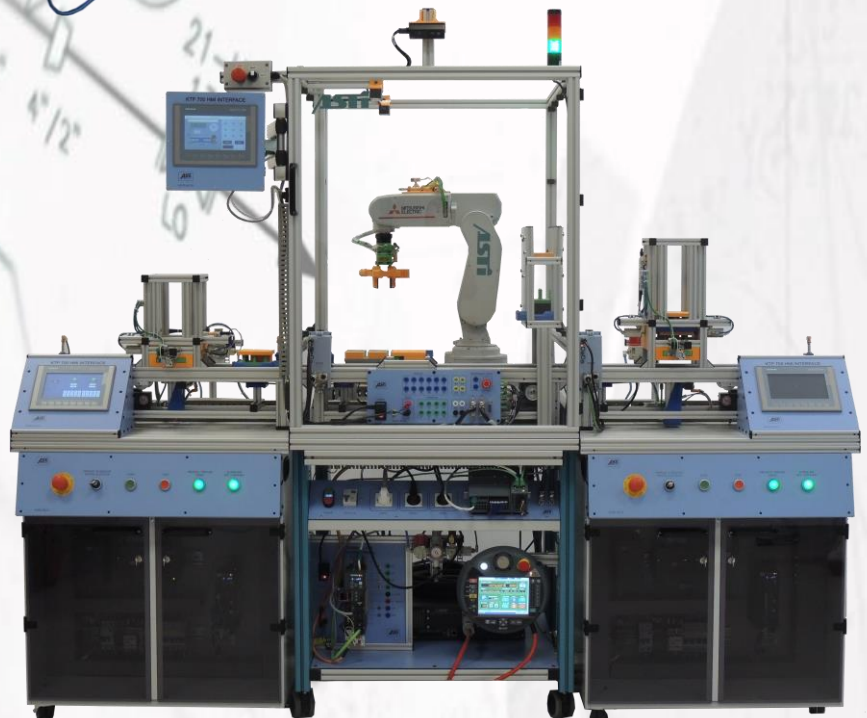

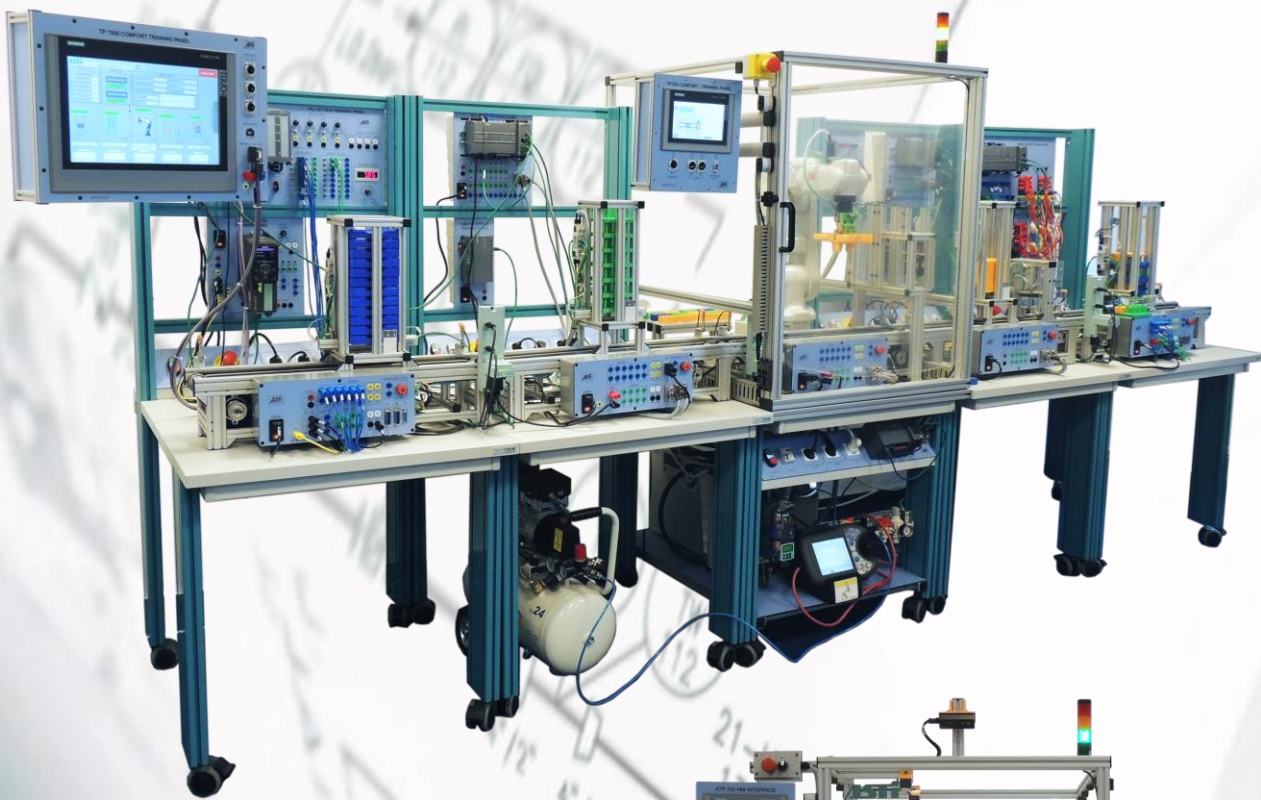

STAY ON TOP OF THE LATEST TECHNOLOGY TRENDS

Technical skills in demand

Staying up to date with the latest technologies assumes engaging in an ongoing learning process. Having well trained and up to date employees is the only way a business can compete in a digitally complex world.

Technical skills are the capabilities that employees need to possess to fulfil their common tasks. Technical training may be required not only for new employees but for all the employees directly involved in technical jobs to keep up with the extensive development of technologies. Most of the time technical skills are job specific.

Develop personnel technical skills

Technical abilities need to be improved by everyone. To deliver the training, you might need to bring in third parties, which doesn't come inexpensive, but technical employment skills training has so many advantages that it should be seen as an investment in the company rather than a cost. Employees who find themselves under-trained are not satisfied. They are more likely to leave their current job and find an employer to invest in them. By comparison, studies confirm that trained employees are much more productive than their untrained counterparts. Promoting skills development builds not only a more productive but also more committed personnel.

Deliver in-house growth

Embed the skills of present and future technologies to get highly skilled personnel with knowledge for the requirements of the business.

Reduce the business risks

Poorly qualified staff pose a risk to themselves and others when, for instance, they are not trained on the correct security practices to be followed when operating hazardous equipment or are under-qualified for their jobs. Thus, skilled personnel ensure a minimized time-to-market and reduce the business risks.

Deliver technical training the right way

Keep in mind that technical training is an ongoing learning process rather than a one-time effort for a company. There are fresh technologies in each industry and to guarantee their importance and significance, employees must remain on top of them.

EVERYONE ULTIMATELY BENEFITS FROM ENHANCED TECHNICAL ABILITIES

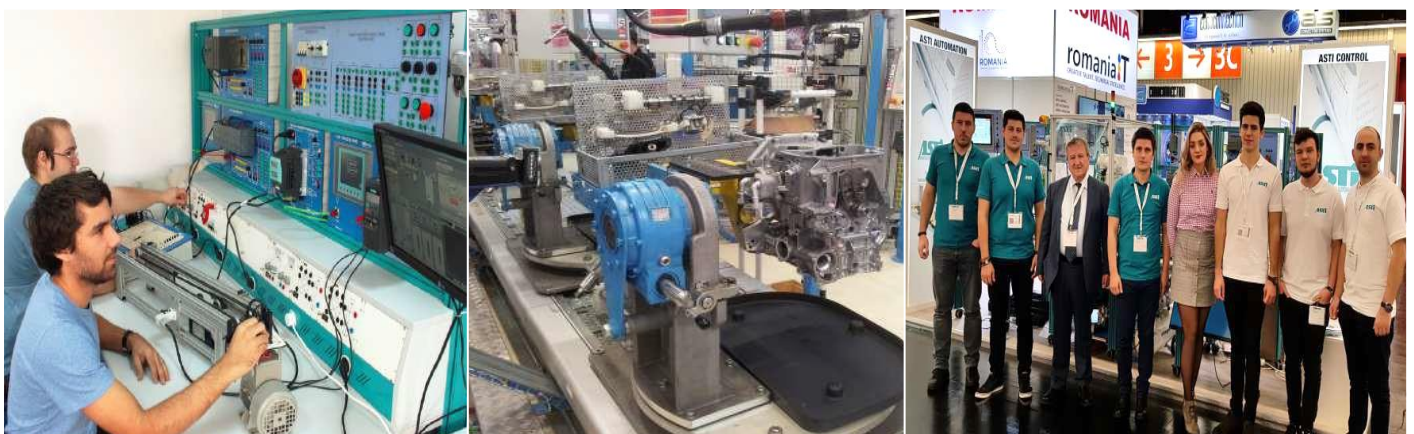
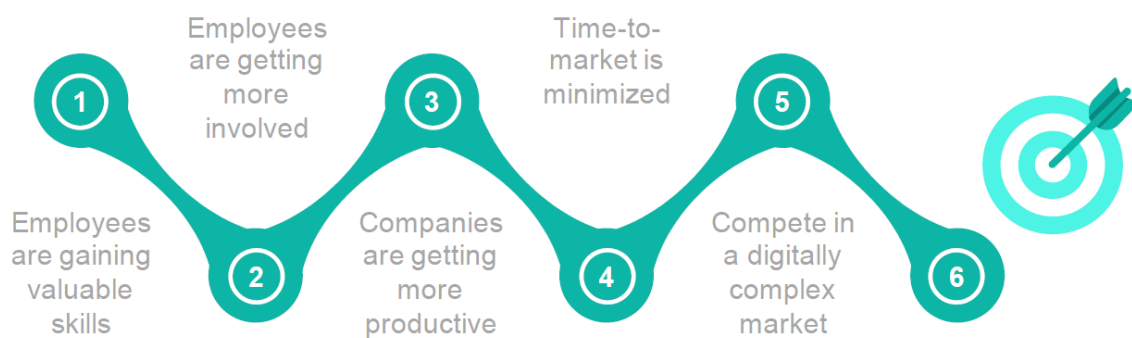

An investment for practical abilities ... An investment for the future!

Cooperates
with Education

SIEMENS

Automation



ASTI Automation SRL, company founded in 2002, is one of the youngest members of the ASTI group. Since 1990, when the first ASTI company was established, ASTI has been a constant promoter of the most advanced automation systems in Romania.

Currently, the company is acting in the industrial automation field, participating in projects from sectors such as oil and gas, automotive, food industry, chemical industry, urban utilities, etc.

Since 2007, the business of the company has been extended through active involvement in increasing the quality of technical education in college and university. The company develops didactic equipment related to approved programs of study, taking into account the current technological level encountered in main industry sectors. The portfolio includes didactic equipment for specific technical fields integrated laboratories mainly for technical universities as well as for companies acting in the industry, training sessions for students or postgraduate courses for professionals in the industry.

Since 2011 ASTI Automation is Siemens SCE partner for training material and a full member of WORLDDIDAC, the global trade association for the education industry.

ASTI Automation complies with the rules of quality management and is certified with ISO 9001: 2008.

ASTI AUTOMATION RELIES ON STRONG PARTNERSHIPS WITH LEADING MANUFACTURERS OF AUTOMATION SOLUTIONS

SIEMENS

rexroth
A Bosch Company

Allen-Bradley

Schneider
Electric

ABB

BECKHOFF



cabur

SICK
Sensor Intelligence.

item

Ott



FESTO

hera
Laborsysteme GmbH



MITSUBISHI



SMC

UNIVERSAL
ROBOTS

WAGO

OUR VALUED CUSTOMERS











AREA OF COMPETENCES

- Sequential Control Systems (#7)
and Programmable Logic Controllers
- Human Machine Interface (#13)
- Industrial Network Communication (#15)
- Safety (#18)
- Electrical Energy Meter Equipment (#20)
- Electrical Installations (#21)
- Electrical and Electronic (#22)
- Drives of Electric Motor
- Advanced Motion Control (#24)
- Conveyors & Technological Control (#26)
- E-Pneumatics (#27)
- Industrial Demo Equipment (#28)
- Data Acquisition, Processing and Monitoring (#29)
- Process Control (#30)
- Industrial Process Simulation (#31)
- Accessories (#32)
- Technical Learning Configurations (#34)
- Training Courses – Skill for industry (#62)
- Content (#79)

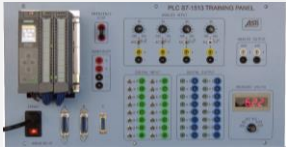
SEQUENTIAL CONTROL SYSTEMS AND PROGRAMMABLE LOGIC CONTROLLERS



<p>AA048.001.03</p> <p>PLC S7-1516 TRAINING PANEL (CPU 1516-3PN/DP) SIEMENS</p>		<p>AA503.000.03</p> <p>PLC S7-1516 TRAINING CASE (CPU 1516-3PN/DP) SIEMENS</p>	
<p>AA503.002.03</p> <p>PLC S7-1516&HMI TRAINING CASE (CPU 1516-3PN/DP & MTP700) SIEMENS</p>		<p>AA048.001.05</p> <p>PLC S7-1512C TRAINING PANEL (CPU 1512C-1PN) SIEMENS</p>	
<p>AA503.000.05</p> <p>PLC S7-1512C TRAINING CASE (CPU 1512C-1PN) SIEMENS</p>		<p>AA503.002.05</p> <p>PLC S7-1512 & HMI TRAINING CASE (CPU 1512C-1PN & MTP700) SIEMENS</p>	
<p>AA048.001.07</p> <p>PLC S7-1513 TRAINING PANEL (CPU 1513-1PN) SIEMENS</p>		<p>AA048.010.07</p> <p>PLC S7-1513 TRAINING PANEL (CPU 1513-1PN) SIEMENS</p>	
<p>AA503.000.07</p> <p>PLC S7-1513 TRAINING CASE (CPU 1513-1PN) SIEMENS</p>		<p>AA503.002.07</p> <p>PLC S7-1513 & HMI TRAINING CASE (CPU 1513-1PN & MTP700) SIEMENS</p>	

AA044.000.07

PLC S7-1215C
TRAINING PANEL
COMPACT
(CPU 1215C)
SIEMENS



AA044.000.03

PLC S7-1215C
TRAINING PANEL
COMPACT
(CPU 1215C)
SIEMENS



AA044.001.01

PLC S7-1215C
TRAINING PANEL
(CPU 1215C)
SIEMENS



AA044.001.02

PLC S7-1215C
TRAINING PANEL
(CPU 1215C)
SIEMENS



AA044.001.03

PLC S7-1215C
TRAINING PANEL
(CPU 1215C)
SIEMENS



AA044.000.04

PLC S7-1215C
TRAINING PANEL
COMPACT
(CPU 1215C)
SIEMENS



AA044.002.02

PLC S7-1212C
TRAINING PANEL
(CPU 1212C)
SIEMENS



AA044.000.06

PLC S7-1214C
TRAINING PANEL
COMPACT
(CPU 1214C)
SIEMENS



AA044.001.05

PLC S7-1214C
TRAINING PANEL
(CPU 1214C)
SIEMENS



AA044.002.03

PLC S7-1212C
TRAINING PANEL
COMPACT
(CPU 1212C)
SIEMENS



AA044.002.04

PLC S7-1212C
TRAINING PANEL
COMPACT
(CPU 1212C)
SIEMENS



AA066.002.02

PLC S7-1215C
TRAINING PANEL
(CPU 1215C RLY &
KTP700)
SIEMENS



AA066.001.01

PLC S7-1215C
TRAINING PANEL
(CPU 1215C &
KTP700)
SIEMENS



AA066.001.02

PLC S7-1215C & HMI
TRAINING PANEL
(CPU 1215C &
KTP700)
SIEMENS



AA066.001.03

PLC S7-1215C & HMI
TRAINING PANEL
(CPU 1215C &
MTP700)
SIEMENS



AA503.002.01

PLC S7-1215C & HMI
TRAINING CASE
(CPU1215C &
KTP700)
SIEMENS



AA503.000.06

PLC S7-1215C
TRAINING CASE
(CPU 1215C)
SIEMENS



AA025.001.04

LOGO! 0BA8
TRAINING PANEL
(DM8, AM2, AQ)
SIEMENS



AA025.000.03

LOGO! 0BA8
TRAINING PANEL
COMPACT
SIEMENS



AA025.002.03

LOGO! 0BA8
DIDACTIC PANEL
COMPACT
SIEMENS



AA062.001.01

ET200SP
(CPU 1512SP)
DIGITAL TRAINING
PANEL
SIEMENS



AA062.001.02

ET200SP
(CPU1512SP)
DISTRIBUTED
TRAINING PANEL
SIEMENS



AA062.002.01

ET200SP
(CPU1510SP)
DIGITAL TRAINING
PANEL
SIEMENS



AA062.002.02

ET200SP
(CPU1510SP)
DISTRIBUTED
TRAINING PANEL
SIEMENS



AA503.001.01

ET200SP
(IM155-6PN)
TRAINING CASE
SIEMENS



AA063.000.02

ET200SP
(IM155-6PN)
DIGITAL TRAINING
PANEL
SIEMENS



AA063.000.05

ET200SP
(IM155-6PN)
TRAINING PANEL
SIEMENS



AA074.000.02

PLC EXTENSION
PANEL

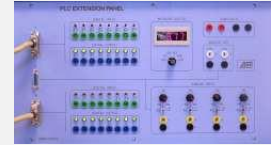

AA020.001.01

PLC CTRLX CORE
TRAINING PANEL
BOSCH



AA061.001.03

PLC S7-314C
TRAINING PANEL
(CPU 314C-2PN/DP)
SIEMENS



AA022.101.01

BECKHOFF PLC CX
TRAINING PANEL
(CX9020)
BECKHOFF



AA022.101.02

BECKHOFF
COUPLER
TRAINING PANEL
(EK1100)
BECKHOFF



AA022.101.03

BECKHOFF
COUPLER
TRAINING PANEL
(EK9000)
BECKHOFF



AA022.100.03

BECKHOFF PLC &
HMI
TRAINING PANEL
(CX9020 & CP6606)
BECKHOFF



AA504.001.01

BECKHOFF PLC &
HMI
TRAINING CASE
(CX9020 & CP6606)
BECKHOFF



AA090.101.03

PLC WAGO
TRAINING PANEL
(CPU 750-8101)
WAGO



AA090.101.04

PLC WAGO
TRAINING PANEL
(CPU 750-890)
WAGO



AA023.001.01

ALLEN BRADLEY
PLC
TRAINING PANEL
(CompactLogix 1769
QBFC1B)
ALLEN BRADLEY



AA023.002.01

ALLEN BRADLEY
PLC
TRAINING PANEL
(CompactLogix 1769
QB1B)
ALLEN BRADLEY



AA024.000.01

ALLEN BRADLEY
PLC
TRAINING PANEL
(ControlLogix 1756
L71)
ALLEN BRADLEY



AA505.000.01

ALLEN BRADLEY
TRAINING CASE
(CompactLogix 1769
+ PANELVIEW 800)
ALLEN BRADLEY



AA505.001.01

ALLEN BRADLEY
TRAINING CASE
(CompactLogix 1769
+ PANELVIEW 800)
ALLEN BRADLEY



AA064.000.02

PLC NEXT
TRAINING PANEL
PHOENIX CONTACT



AA025.000.05

NANOLINE
TRAINING PANEL
(COMPACT)
PHOENIX CONTACT



AA025.001.07

NANOLINE
TRAINING PANEL
PHOENIX CONTACT



AA051.002.01

PLC M221
TRAINING PANEL
(CPUTM221ME32TK
& HMIST6400)
SCHNEIDER



AA051.001.01

PLC M221
TRAINING PANEL
(CPU
TM221ME32TK)
SCHNEIDER



AA051.000.01

PLC M221
TRAINING PANEL
(CPUTM221ME32TK)
SCHNEIDER



AA025.001.11

ZELIO
TRAINING PANEL
SCHNEIDER



AA025.000.10

ZELIO
TRAINING PANEL
SCHNEIDER

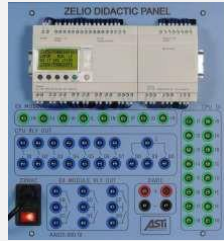

AA052.001.01

PLC X20
TRAINING PANEL
(CPU X20CP0482)
B&R



AA052.001.02

PLC X20
TRAINING PANEL
(CPU X20CP1586)
B&R



AA052.002.01

PLC X20
TRAINING PANEL
(CPU X20CP0482
& HMI T30)
B&R



AA052.002.02

PLC X20
TRAINING PANEL
(CPU X20CP1586
& HMI T30)
B&R



AA052.003.01

PLC X20
TRAINING PANEL
(CPU X20CP0482
& HMI T50)
B&R



AA052.003.02

PLC X20
TRAINING PANEL
(CPU X20CP1586
& HMI T50) B&R



AA078.000.01

PLC S7-412
TRAINING PANEL
SIEMENS



HUMAN MACHINE INTERFACE



<p>AA071.000.04</p> <p>HMI MTP1500 UNIFIED COMFORT TRAINING CASE SIEMENS</p>		<p>AA071.001.04</p> <p>HMI MTP1500 UNIFIED TRAINING CASE WITH FLEXIBLE SUPPORT SIEMENS</p>	
<p>AA071.000.06</p> <p>HMI TP1200 COMFORT TRAINING PANEL SIEMENS</p>		<p>AA071.001.06</p> <p>HMI TP1200 COMFORT TRAINING CASE WITH FLEXIBLE SUPPORT SIEMENS</p>	
<p>AA071.000.05</p> <p>HMI MTP700 UNIFIED COMFORT TRAINING PANEL SIEMENS</p>		<p>AA071.001.05</p> <p>HMI MTP700 UNIFIED COMFORT CASE WITH FLEXIBLE SUPPORT SIEMENS</p>	
<p>AA071.002.05</p> <p>HMI MTP700 UNIFIED COMFORT CASE FOR CPS SIEMENS</p>		<p>AA071.000.03</p> <p>HMI MTP1500 UNIFIED COMFORT TRAINING PANEL SIEMENS</p>	
<p>AA071.001.03</p> <p>HMI MTP1500 UNIFIED TRAINING CASE WITH FLEXIBLE SUPPORT SIEMENS</p>		<p>AA071.003.01</p> <p>MTP700 HMI INTERFACE CASE SIEMENS</p>	

AA026.000.03

HMI KTP700
TRAINING PANEL
SIEMENS



AA026.001.03

HMI KTP700
TRAINING CASE
WITH FLEXIBLE
SUPPORT
SIEMENS



AA026.002.03

HMI KTP700
CASE (CPS)
SIEMENS



AA026.002.04

KTP700 HMI
INTERFACE CASE
SIEMENS



AA027.000.01

HMI CP6606
TRAINING PANEL
BECKHOFF



AA072.000.01

HMI T30
TRAINING PANEL
B&R



AA072.000.02

HMI T50
TRAINING PANEL
B&R



AA030.000.01

HMI
HMIST6400
TRAINING PANEL
SCHNEIDER



AA029.000.01

HMI
PANELVIEW 800
TRAINING PANEL
ALLEN BRADLEY



AA029.000.02

HMI
PANELVIEW PLUS 7
TRAINING PANEL
ALLEN BRADLEY



AA021.001.01

HMI
PANELVIEW 800
TRAINING PANEL
ALLEN BRADLEY

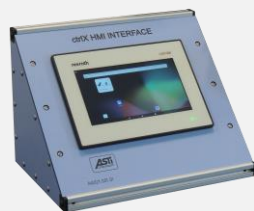

INDUSTRIAL NETWORK COMMUNICATION



<p>AA073.001.03</p> <p>PLC COMMUNICATION TRAINING PANEL (S7-1200) SIEMENS</p>		<p>AA054.400.01</p> <p>NETWORK SECURITY TRAINING PANEL SIEMENS</p>	
<p>AA503.002.02</p> <p>PLC S7-1215C & HMI COMMUNICATION TRAINING CASE (KTP700) SIEMENS</p>		<p>AA504.000.02</p> <p>PLC & HMI COMMUNICATION TRAINING CASE (CX9020 & CP6606) BECKHOFF</p>	
<p>AA073.001.01</p> <p>PLC S7-1215C CANOPEN TRAINING PANEL (CPU1215C) SIEMENS</p>		<p>AA073.001.02</p> <p>PLC S7-1215C IO-LINK TRAINING PANEL (CPU1215C) SIEMENS</p>	
<p>AA054.300.01</p> <p>MINDCONNECT NANO PANEL SIEMENS</p>		<p>AA054.300.02</p> <p>SIMATIC INDUSTRIAL EDGE PANEL SIEMENS</p>	
<p>AA054.200.02</p> <p>SIMATIC IOT2050 TRAINING PANEL SIEMENS</p>			

AA054.001.01

IE SCALANCE XC208
SWITCH PANEL
SIEMENS



AA054.000.01

IWLAN ACCESS
POINT
SIEMENS



AA023.000.02

IO-LINK
COMMUNICATION
TRAINING PANEL
ALLEN BRADLEY



AA093.000.01

PLC CECC - LK
COMM.TRAINING
PANEL
FESTO



AA063.000.03

ET200SP
(IM155-6PN)
Digital IO-Link
Training Panel
SIEMENS



AA073.100.01

IO-LINK MOTOR
STARTER TRAINING
PANEL
SIEMENS



AA063.100.01

ET200S PN MOTOR
STARTER TRAINING
PANEL
(PN COUPLER)
SIEMENS



AA063.000.04

ET200SP (IM155-6PN)
DIGITAL AS-I
TRAINING PANEL
SIEMENS



AA060.000.03

IO-LINK MASTER
(PN/ETHERCAT)
TRAINING PANEL
IFM



AA060.000.05

IO-LINK MASTER
(PROFINET) &
DIGITAL I/O PANEL
IFM



AA073.001.04

SIEMENS (S7-1200)
COMMUNICATIONS
TRAINING PANEL
SIEMENS



AA060.000.10

PROFINET IO-LINK
MASTER PANEL
(DIO, IO-LINK)
IFM



AA060.000.11

PROFIBUS IO-LINK MASTER PANEL (DIO, IO-LINK) IFM



AA060.000.12

MODBUS TCP IO-LINK MASTER PANEL (DIO, IO-LINK) IFM



AA060.000.13

ETHERCAT IO-LINK MASTER PANEL (DIO, IO-LINK) IFM



AA060.000.14

ETHERNETIP IO-LINK MASTER PANEL (DIO, IO-LINK) IFM



AA060.101.01

IO-LINK TEMPERATURE TRANSMITTER PANEL IFM



AA060.101.02

CANOPEN RFID ANTENNA PANEL IFM



AA060.101.03

IO-LINK RFID ANTENNA PANEL IFM



AA022.201.01

BECKHOFF COMMUNICATIONS TRAINING PANEL (COUPLER) BECKHOFF



AA022.301.01

DEVICENET DIGITAL IO PANEL BECKHOFF



AA022.301.02

CANOPEN DIGITAL IO PANEL BECKHOFF



AA050.000.01

REMOTE COMMUNICATION PANEL (SITEMANAGER) SECOMEA



AA050.100.01

REMOTE COMMUNICATION LICENSE (LINKMANAGER) SECOMEA





AA048.001.04

PLC S7-1516F
TRAINING PANEL
(CPU 1516F-
3PN/DP)
SIEMENS



AA503.002.04

PLC S7-1516F &
HMI TRAINING
CASE (CPU-1516F-
3PN/DP & MTP700)
SIEMENS



AA062.000.01

ET200SP (CPU
1512SP F) DIGITAL
TRAINING PANEL
SIEMENS



AA062.000.02

ET200SP (CPU
1512SP F)
DISTRIBUTED
TRAINING PANEL
SIEMENS



AA062.000.03

ET200SP
(CPU1512SP-F)
SAFETY TRAINING
PANEL
SIEMENS



AA062.000.04

F-PLC TRAINING
PANEL AND MOTOR
CONTROL
(CPU 1512SP)
SIEMENS

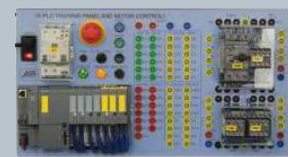

AA062.003.01

ET200SP (CPU
1510SP F) DIGITAL
TRAINING PANEL
SIEMENS



AA062.003.02

ET200SP (CPU
1510SP F)
DISTRIBUTED
TRAINING PANEL
SIEMENS



AA062.003.03

ET200SP (CPU
1510SP F) SAFETY
TRAINING PANEL
SIEMENS



AA062.003.04

F-PLC TRAINING
PANEL AND MOTOR
CONTROL
(CPU 1510SP)
SIEMENS



AA061.001.04

PLC S7-317F
SAFETY TRAINING
PANEL (CPU317F-
2PN/DP)
SIEMENS



AA076.000.01

PLC S7-315F
SAFETY TRAINING
PANEL (CPU315F-
2PN/DP)
SIEMENS



AA080.000.01

I/O SAFETY
TRAINING PANEL
SIEMENS



AA077.000.01

ET200SP
(CPU1512SP-F)
SAFETY TRAINING
SYSTEM
SIEMENS



AA060.000.02

AS-I AC402S
TRAINING PANEL
IFM



AA081.000.01

SAFETY TRAINING
SYSTEM
SIEMENS

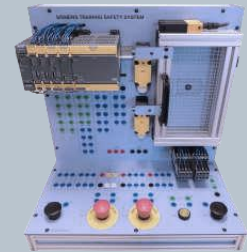

AA402.000.01

SAFETY
CONNECTION
CABLES 4MM 0.5M



AA402.000.02

SAFETY
CONNECTION
CABLES 4MM 1M



AA081.001.02

SAFETY RELAY
TRAINING PANEL
SIEMENS

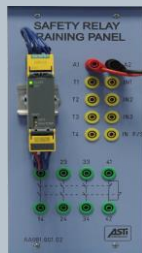

AA081.002.02

SAFETY RELAY
OUTPUT
EXTENSION
SIEMENS

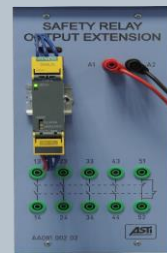

AA503.000.04

PLC S7-1516F
TRAINING CASE
(CPU 1516F-
3PN/DP)
SIEMENS



AA074.100.01

I/O TRAINING
PANEL



ELECTRICAL ENERGY METER EQUIPMENT

AA089.001.01

ENERGY METER
TRAINING CASE
(CPU 1215C)
SIEMENS



AA089.001.02

ENERGY METER
TRAINING PANEL
(CPU 1215C)
SIEMENS



AA089.002.03

ENERGY METER
TRAINING PANEL
(CPU 1512SP)
SIEMENS



AA089.002.02

ENERGY METER
TRAINING PANEL
(CPU 1510SP)
SIEMENS



AA089.030.01

ENERGY
MANAGEMENT
SYSTEM (3AC)
SIEMENS



AA089.010.01

ENERGY
MANAGEMENT
SYSTEM (1AC)
SIEMENS



AA088.000.03

SENTRON
PAC5200 ENERGY
MEASUREMENT
TRAINING PANEL
SIEMENS



AA088.000.02

SENTRON
PAC4200 ENERGY
MEASUREMENT
TRAINING PANEL
SIEMENS



AA088.100.01

SENTRON PAC3220
ENERGY
MEASUREMENT
TRAINING PANEL
SIEMENS



ELECTRICAL INSTALLATIONS



<p>AA500.001.02</p> <p>TRAINING CONTROL CABINET (S7-1215C) SIEMENS</p>		<p>AA500.000.01</p> <p>TRAINING CONTROL CABINET (LOGO! 0BA8) SIEMENS</p>	
<p>AA500.100.01</p> <p>TRAINING CONTROL CABINET (LOGO! 0BA8) SIEMENS</p>		<p>AA204.000.01</p> <p>TRAINING SYSTEM FOR ELECTRICAL INSTALATIONS</p>	
<p>AA203.000.01</p> <p>TRAINING SYSTEM FOR RESIDENTIAL ELECTRICAL INSTALLATION</p>		<p>AA041.001.01</p> <p>ENERGY METER EEM MA250 TRAINING PANEL Phoenix Contact</p>	
<p>AA055.000.01</p> <p>POWER SUPPLY 24VDC, 3A</p>		<p>AA055.100.01</p> <p>POWER BATTERY 12/24V 1.3AH</p>	
<p>AA068.000.01</p> <p>UPS PANEL PHOENIX CONTACT</p>		<p>AA083.000.01</p> <p>DRIVE POWER PANEL (DC VARIABLE VOLTAGE)</p>	

ELECTRICAL AND ELECTRONIC DRIVES OF ELECTRIC MOTORS



AA042.000.02

SINAMICS G120 PN
TRAINING PANEL
(1AC, 230V, 0.37 kW)
SIEMENS



AA042.000.03

SINAMICS G120 PN
TRAINING PANEL
(1AC, 230V, 0.37 kW)
SIEMENS



AA042.000.04

SINAMICS G120 PN
TRAINING PANEL
(1AC, 230V, 1.5 kW)
SIEMENS



AA042.001.01

SINAMICS G120X
TRAINING PANEL
(3AC, 400V, 0.75 kW)
SIEMENS



AA042.001.02

SINAMICS G120PN
TRAINING PANEL
(3AC, 400V, 0.55 kW)
SIEMENS



AA042.001.03

SINAMICS G120 PN
TRAINING PANEL
(3AC, 400V, 0.55kW)
SIEMENS



AA042.001.04

SINAMICS G120 PN
TRAINING PANEL
(3AC, 400V, 1.5 kW)
SIEMENS



AA042.001.05

SINAMICS G120C PN
TRAINING PANEL
(3AC, 400V, 0.75kW)
SIEMENS



AA042.011.04

SINAMICS G120 PN
TRAINING PANEL
(3AC, 400V, 1.5kW,
ENCODER)
SIEMENS



AA042.002.02

SINAMICS V20
MODBUS
TRAINING PANEL
(3AC, 400V, 0.55kW)
SIEMENS



<p>AA042.003.02</p> <p>SINAMICS V20 MODBUS TRAINING PANEL (1xAC,230V,0.37kW) SIEMENS</p>		<p>AA205.000.03</p> <p>TRAINING SYSTEM AC MOTOR & ENC (1AC G120PN, 3xAC,0.37kW ENC) SIEMENS</p>	
<p>AA205.001.03</p> <p>TRAINING SYSTEM AC MOTOR & ENC (3AC G120PN, 3xAC,0.37kW ENC) SIEMENS</p>		<p>AA205.003.04</p> <p>TRAINING SYSTEM AC MOTOR (3AC G120PN, 3AC, 1.5 kW) SIEMENS</p>	
<p>AA205.013.04</p> <p>TRAINING SYSTEM AC MOTOR (3AC, G120PN, 3AC,1.5kW ENC) SIEMENS</p>		<p>AA205.002.03</p> <p>TRAINING SYSTEM AC MOTOR (3AC, V20 3xAC, 0.37 kW) SIEMENS</p>	
<p>AA081.000.04</p> <p>SINAMICS G120 TRAINING SYSTEM (1AC, G120PN, 3AC, 0.37 kW ENC) SIEMENS</p>		<p>AA010.000.02</p> <p>MOTOR CONTROL TRAINING PANEL 3AC Power SUPPLY SIEMENS</p>	
<p>AA011.000.02</p> <p>MOTOR CONTROL TRAINING PANEL CONTROL UNIT</p>		<p>AA017.100.09</p> <p>AC MOTOR & ENCODER (3AC MOTOR, 0.37 kW ENC) SIEMENS</p>	
<p>AA018.100.01</p> <p>3AC ASYNC. MOTOR 1.5kW 4 POLE 1480 RPM</p>		<p>AA086.000.01</p> <p>SINAMICS DCM TRAINING SYSTEM DC MOTOR & TACHOMETER SIEMENS</p>	

ADVANCED MOTION CONTROL



<p>AA046.000.01</p> <p>SINAMICS S210 TRAINING PANEL (1AC, 230V, 0.4 kW) SIEMENS</p>		<p>AA046.001.01</p> <p>TRAINING SYSTEM with SERVOMOTOR (1AC S210, 1FK2 0.4 kW) SIEMENS</p>	
<p>AA046.002.01</p> <p>TRAINING SYSTEM MOTION CONTROL (2x 1AC S210, 2x 1FK2, 0.4kW) SIEMENS</p>		<p>AA046.003.02</p> <p>SINAMICS S210 2xAXIS DRIVE PANEL (2x 1AC S210, 0.4kW) SIEMENS</p>	
<p>AA046.003.03</p> <p>SINAMICS S210 3xAXIS DRIVE PANEL (3x 1AC S210, 0.4kW) SIEMENS</p>		<p>AA045.000.01</p> <p>SINAMICS V90 TRAINING PANEL (1AC, 230V, 0.4 kW) SIEMENS</p>	
<p>AA045.001.01</p> <p>TRAINING SYSTEM with SERVOMOTOR (1xAC V90, SERVO 1FL6 0.4kW) SIEMENS</p>		<p>AA045.002.01</p> <p>TRAINING SYSTEM MOTION CONTROL (2x1AC V90, 2x 1FL6 0.4 kW) SIEMENS</p>	
<p>AA045.003.02</p> <p>SINAMICS V90 2xAXIS DRIVE PANEL (2x1AC V90, 0.4kW) SIEMENS</p>		<p>AA045.003.03</p> <p>SINAMICS V90 3xAXIS DRIVE PANEL (3x1AC V90, 0.4kW) SIEMENS</p>	

AA094.000.01

SINAMICS S120
TRAINING PANEL
(1xAC, 230V,
0.4kW)
SIEMENS

**AA094.001.01**

TRAINING
SYSTEM with
SERVOMOTOR
(1AC, S120, 1FK7.
0.4 kW)
SIEMENS

**AA047.000.01**

SINAMICS S200
TRAINING PANEL
(1xAC, 230V, 0.4kW)
SIEMENS

**AA047.001.01**

TRAINING SYSTEM
with SERVOMOTOR
(1xAC S200, 1FL2,
0.4kW)
SIEMENS

**AA047.002.01**

MOTION CONTROL
SINAMICS S200
TRAINING SYSTEM
(1FL2, 0.4kW)
SIEMENS

**AA047.003.02**

SINAMICS S200
2xAXIS DRIVE
PANEL (2X 1AC
S200, 0.4kW)
SIEMENS

AA047.003.03

SINAMICS S200
3xAXIS DRIVE
PANEL (3x 1AC
S200, 0.4kW)
SIEMENS

**AA019.003.02**

INDRADRIVE CS
TRAINING PANEL
(2xAXIS)
BOSCH REXROTH

**AA049.001.01**

PLC S7-1511T
TRAINING PANEL
(CPU1511T-1PN)
SIEMENS

**AA044.001.04**

PLC TRAINING
PANEL & MOTOR
CONTROL
SIEMENS

**AA017.300.01**

SOFT STARTER
TRAINING PANEL
(1.5 kW, 400 V)
SIEMENS

**AA017.400.01**

SOFT STARTER
TRAINING CASE
SIEMENS



CONVEYORS & TECHNOLOGICAL CONTROL

<p>AA094.101.01</p> <p>CONVEYOR TOOTHED BELT Synchronous Servo (S120,1FK7,0.4 kW) SIEMENS</p>		<p>AA094.101.19</p> <p>CONVEYOR TOOTHED BELT Synchronous Servo (S210,1FK2,0.4kW) SIEMENS</p>	
<p>AA094.101.20</p> <p>CONVEYOR TOOTHED BELT Synchronous Servo (S200,1FL2,0.4kW) SIEMENS</p>		<p>AA094.101.06</p> <p>CONVEYOR TOOTHED BELT Synchronous Servo (V90,1FL6,0.4kW) SIEMENS</p>	
<p>AA094.101.08</p> <p>CONVEYOR TOOTHED BELT OTT BRUSH DC SERVO DRIVE CAN OTT</p>		<p>AA094.101.04</p> <p>CONVEYOR TOOTHED BELT Asynchronous 3AC MOTOR OTT</p>	
<p>AA094.101.14</p> <p>CONVEYOR TOOTHED BELT Asynchronous 3AC (3x230/400) Motor OTT</p>		<p>AA094.101.18</p> <p>CONVEYOR TOOTHED BELT Synchronous Servo (0.1 kW) INDRADRIVE</p>	
<p>AA097.003.01</p> <p>CONVEYOR TECH Flat BELT (120mm) (CENTRAL DRIVE) TECH</p>		<p>AA097.003.02</p> <p>CONVEYOR TECH Flat BELT (120mm) (END DRIVE) TECH</p>	



AA095.000.01

COMPACT
PNEUMATIC
PALLET STORAGE
UNIT



AA095.000.02

COMPACT
PNEUMATIC BASE
PIECE STORAGE
UNIT



AA095.000.03

COMPACT
PNEUMATIC TOP
PIECE STORAGE
UNIT



AA095.000.04

PRESS PIECES UNIT



AA095.000.05

COMPACT
PNEUMATIC INDEX
UNIT



AA095.000.06

COMPACT
PNEUMATIC
STORAGE UNIT



AA059.000.08

E-PNEUMATIC
SMC TRAINING
SYSTEM
SMC



AA059.000.10

E-PNEUMATIC
FESTO TRAINING
SYSTEM
FESTO

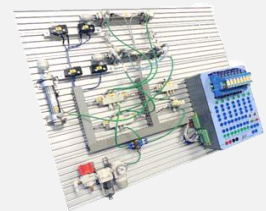

AA059.000.05

SMART RELAY
E-PNEUMATIC
(LOGO! 0BA8)
SIEMENS



AA059.000.04

SMART RELAY
E-PNEUMATIC
(NANOLINE)
PHOENIX
CONTACT



AA059.001.08

SMART ENERGY
E-PNEUMATIC
PANEL
SMC



AA096.001.04

DOUBLE GRIPPER
FOR TRAINING
ROBOT
SMC



AA096.001.03

GRIPPER FOR
TRAINING ROBOT
SMC



AA059.000.06

AIR SUPPLY
FILTER
REGULATOR
SMC



INDUSTRIAL DEMO EQUIPMENT

AA008.000.01

SERVODRIVE
TRAINING CASE
(MINI-SLIDE
ACTUATOR)
FESTO



AA008.000.02

SERVODRIVE
TRAINING CASE
(TOOTHED BELT
AXIS)
FESTO



AA008.000.03

PLC FESTO & HMI
TRAINING CASE
FESTO



AA008.000.04

3xAXIS CARTESIAN
ROBOT DEMO CASE
FESTO



AA007.000.09

CMMP-AS MOTION
CONTROL TRAINING
PANEL (SERVO)
FESTO



AA007.000.10

CMMS-ST MOTION
CONTROL TRAINING
PANEL (STEPPER)
FESTO



DATA ACQUISITION PROCESSING AND MONITORING



<p>AA001.001.01</p> <p>DATA ACQUISITION TRAINING PANEL (NI USB 6001) NATIONAL INSTRUMENTS</p>		<p>AA001.002.01</p> <p>DATA ACQUISITION TRAINING PANEL (NI USB 6002) NATIONAL INSTRUMENTS</p>	
<p>AA031.010.04</p> <p>VALS SIEMENS CONDITION MONITORING (S7-1281) SIEMENS</p>		<p>AA031.010.05</p> <p>VALS IFM CONDITION MONITORING (VSE 150) IFM</p>	
<p>AA506.000.01</p> <p>MAGNETIC HYSTERESIS CYCLE MEAS.(B/H) EQUIPMENT</p>		<p>AA056.001.01</p> <p>HART TEMPERATURE TRANSMITTER BOARD (SITRANS TH300) SIEMENS</p>	
<p>AA056.002.01</p> <p>PROFIBUS PA TEMPERATURE TRANSMITTER BOARD (SITRANS TH400) SIEMENS</p>		<p>AA056.100.01</p> <p>HART USB CONFIGURATOR MULLER</p>	
<p>AA044.200.01</p> <p>TIM 4R-IE TRAINING PANEL SIEMENS</p>		<p>AA074.000.01</p> <p>EDUKIT PA EXTENSION PANEL</p>	

PROCESS CONTROL

<p>AA087.000.02</p> <p>COUPLED TANK SYSTEM ASTANK-2 (L, F, P, T)</p>		<p>AA092.001.01</p> <p>INVERTED PENDULUM LINEAR SYSTEM</p>	
<p>AA092.002.01</p> <p>BALL AND BEAM SYSTEM</p>		<p>AA092.003.01</p> <p>BALL BALANCING TABLE WITH MATLAB SUPPORT</p>	
<p>AA092.004.01</p> <p>1-DOF HELICOPTER WITH MATLAB SUPPORT</p>		<p>AA092.005.01</p> <p>STEWART PLATFORM (PROGRAMMING IN MATLAB)</p>	
<p>AA087.010.03</p> <p>PLC S7-1516 TRAINING PANEL ASTANK-2 SIEMENS</p>		<p>AA087.011.02</p> <p>PLC S7-1215C TRAINING PANEL ASTANK-2 SIEMENS</p>	
<p>AA090.001.01</p> <p>WAGO 750-8101 DAQ TRAINING PANEL ASTANK-2 BECKHOFF</p>		<p>AA022.000.02</p> <p>COUPLER TRAINING PANEL (EK9000) ASTANK-2 BECKHOFF</p>	

INDUSTRIAL PROCESS SIMULATION

AA600.101.04

PROSIM V+ SMART
DIGITAL
PROCESSES
SIEMENS

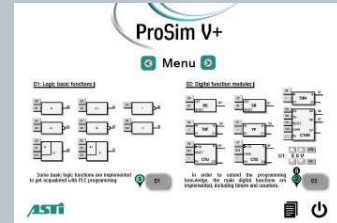
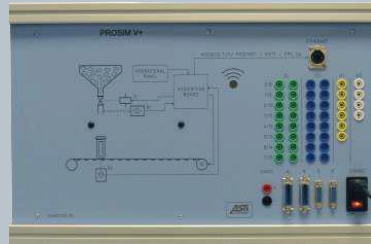

AA600.102.01

PROSIM V+ 10.5
INCH TABLET
DISPLAY

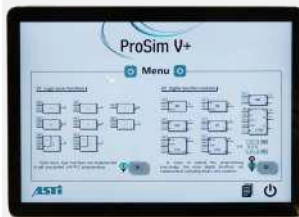

AA600.103.01

PROSIM V+ ALL IN
ONE PC 23.8" I5
TOUCH

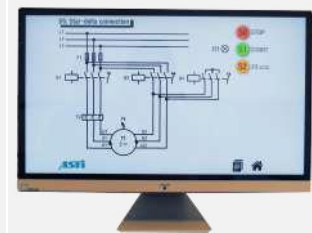

**D5: STAR-DELTA
CONNECTION**

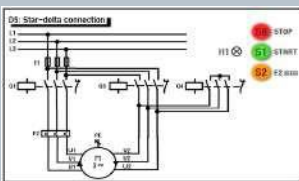

**D11: CONVEYOR BELT
SYSTEM**

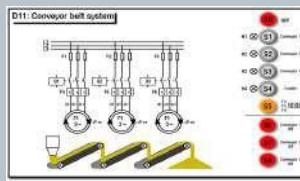

**D15: AUTOMATIC FILLING
SYSTEM**

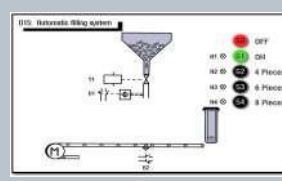

D16: TANK SYSTEM

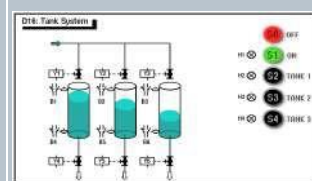

**D18: EMBOSsing
MACHINE**

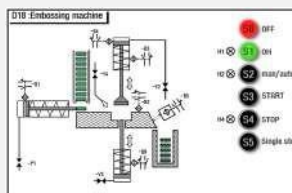

D21: TRAFFIC LIGHTS



D23: SILO CONTROL

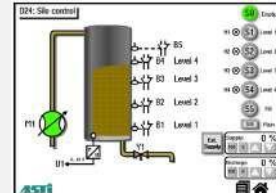

D25: REACTOR

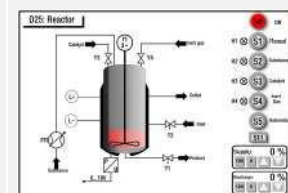

D27: PUMP CONTROL

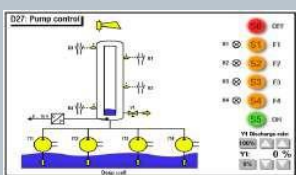

D30: DRINKS MACHINE



**D33: SEQUENCE
CONTROL**

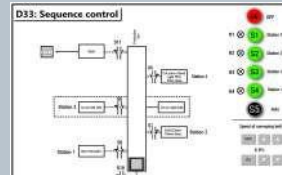

D34: ELEVATOR

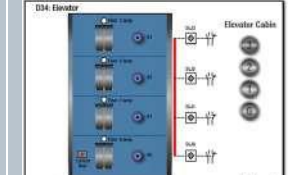

ACCESSORIES

<p>AA200.001.01</p> <p>WORKSTATION (2000 x 800 x750) with 1AC MODULAR SUPPLY PANEL</p>		<p>AA200.003.01</p> <p>WORKSTATION (2000 x 800 x750) with 3AC MODULAR SUPPLY PANEL</p>	
<p>AA200.000.02</p> <p>COMPACT WORKSTATION with WHEELS & MODULAR SUPPLY PANEL SIZE (WxH) 800 x 1000 mm</p>		<p>AA200.001.02</p> <p>WORKSTATION FOR ROBOTCELL (ABB MITSUBISHI) WITH MODULAR SUPPLY PLANEL</p>	
<p>AA200.001.03</p> <p>WORKSTATION FOR ROBOTCELL (UR3E CRB1100) WITH MODULAR SUPPLY PLANEL</p>		<p>AA200.000.04</p> <p>TABLE-TOP STAND with MODULAR 3AC SUPPLY PANEL SIZE (WxH) 910x790 mm</p>	
<p>AA200.000.05</p> <p>TABLE-TOP STAND with MODULAR 1AC SUPPLY PANEL SIZE (WxH) 910x790 mm</p>		<p>AA200.000.06</p> <p>TABLE-TOP STAND with MODULAR 1AC SUPPLY PANEL SIZE (WxH) 910x1100 mm</p>	
<p>AA200.000.03</p> <p>TABLE-TOP STAND SIZE (WxH) SIZE (WxH) 910x790 mm</p>		<p>AA200.000.15</p> <p>TABLE-TOP STAND with Modular 1AC Supply Panel & PAC 1600</p>	

<p>AA200.002.02</p> <p>WORKSTATION FOR ADVANCED MECHATHRONICS LAB</p>		<p>AA028.001.02</p> <p>TRAFFIC SIGNAL PANEL</p>	
<p>AA089.100.02</p> <p>SOCKETS PANEL</p>		<p>AA096.001.05</p> <p>CAGE FOR TRAINING ROBOT</p>	
<p>AA059.000.09</p> <p>AIR COMPRESSOR SUPERSILENT STAGER</p>		<p>AA095.100.01</p> <p>3D PRINTED PIECES (SET WITH TAG)</p>	
<p>AA095.101.01</p> <p>3D PRINTED PIECE (PALLET WITH TAG)</p>		<p>Case Alum-1</p> <p>ALUMINIUM CASE (INTERNAL SIZE (WxHxD): 505 x 455 x 115mm)</p>	
<p>Case HPRC-1</p> <p>CASE HPRC-1 CUBED FOAM (WxHxD)int (749 x 525 x 366mm)</p>		<p>Case HPRC-2</p> <p>CASE HPRC-2 CUBED FOAM (WxHxD)int (509X460X316 mm)</p>	
<p>AA402.000.03</p> <p>I/O DATA CABLE WITH SYSLINK CONNECTORS</p>		<p>AA402.000.04</p> <p>ANALOG CABLE PARALLEL</p>	

TECHNICAL LEARNING CONFIGURATIONS



AA096.001.01/AA096.002.01/AA096.003.01 /AA096.004.01

INTEGRATED 6 AXIS ROBOT TRAINING STATIONS

Description:

The Integrated 6 Axis Robot Training Stations is a didactic system which is built around a 6-axis industrial robot and an industrial small-scaled conveyor belt with 1FL2 servomotor. The Integrated 6 Axis Robot Training Station gives the opportunity to learn practical applications of closed loop speed and position control via the S200 driver. The pallets that are transported on the conveyor belt are fitted with an identification RFID Tag containing a unique identification code that can be both read and modified via the Siemens RF series RFID Readers. The process synchronization is assured by a SIEMENS S7-1200 PLC and the HMI KTP700. The station can assemble and disassemble the work piece thus being able to work for an indefinite time.

- AA096.001.01 - ABB IRB-1100, OmniCore Compact controller, PN
- AA096.002.01 - MITSUBISHI RV-2FR, CR800 controller, PN
- AA096.003.01 –UNIVERSAL ROBOT UR3E controller PN_IFM VISION CONTROL 3D
- AA096.004.01 - ABB CRB 1100, Compact Controller, PN

The structure includes (main pieces):

- 6 Axis Robot
- Vision Control 3D only for AA096.003.01
- AA200.001.02 – Workstation MR (800 x 800 x 750) with Modular Supply Panel
- Siemens PLC S7-1200
- RFID System IO-LINK
- AA026.001.03 - HMI KTP700 TRAINING CASE with Flexible Support
- AA096.001.04 - Double Gripper E-PNEUM & VACUUM (SMC)
- AA094.101.20 – CONVEYOR TOOTHED BELT WITH SERVO (S200/1FL2)
- AA047.000.01 - SINAMICS S200 Panel (3xAC Servo 0.4kW)
- AA096.001.05 - CAGE (safety for ROBOT only ABB iRB120 & Mitsubishi)
- AA095.000.05 - Compact Pneumatic INDEX UNIT
- AA059.000.06 - Air Supply Filter Regulator with pressure switch
- AA059.000.09 - Air Compressor Super silent SAGER
- AA095.100.01 – 6 x 3D Printed Assembly Line Set



Practice:

- 3D product assembly with 6 axis industrial robot
- Controlling the process using SIMATIC S7-1200 & HMI KTP700
- Controlling the Servo motor of the conveyor belt using SINAMICS S200 Servo Drive

Optional equipment:

- AA054.200.02 - SIMATIC IOT2050 TRAINING PANEL SIEMENS
- AA054.001.01 - IE SCALANCE SWITCH SIEMENS

AA100.101.06/AA100.101.08/ AA100.101.014 AA100.101.18/ AA100.101.19/ AA100.101.20 CYBER PHYSICAL SYSTEMS

Description:

The **CYBER PHYSICAL SYSTEM** is a state-of-the-art industrial automation system that combines cutting-edge technology with a durable and mobile design. The system includes a high-performance servomotor, powered by a SIEMENS SINAMICS driver for efficient movement. The system also includes a variety of advanced control and monitoring equipment such as a Siemens PAC1600, SIMATIC S7-1200 PLC and RFID antenna from IFM. The system also includes a SIEMENS SIMATIC IoT2050 and an HMI KTP700 CASE PANEL (CPS) SIEMENS for easy monitoring and control. The system also includes a conveyor belt, which is designed for heavy-duty use, as well as two IFM inductive sensors for precise positioning.

- AA100.101.06 CPS with Conveyor 2xToothed Belt (120 mm Servomotor 1FL6) / Sinamics V90 Inverter
- AA100.101.08 CPS with Conveyor 2xToothed Belt (120 mm DC Servomotor)/ Drive/ CanOpen Communication
- AA100.101.14 CPS with Conveyor 2xToothed Belt (120mm ,3AC Asynchronous Motor ,Inverter)
- AA100.101.18 CPS with Conveyor 2xToothed Belt (120 mm Servomotor IndraDrive) / Bosch Rexroth Inverter
- AA100.101.19 CPS with Conveyor 2xToothed Belt (120 mm Servomotor 1FK2) / Sinamics S210 Inverter
- AA100.101.20 CPS with Conveyor 2xToothed Belt (120 mm Servomotor 1FL2) / Sinamics S200 Inverter

The structure includes (main pieces):

- STEEL STRUCTURE (2 doors trolley: 700 x 700 x 750 mm) with HPL Panels and 4 Swivel Casters
- SIEMENS SIMATIC PLC (CPU 1215C PN) / Power Supply DC 24V,10A
- SIEMENS SIMATIC IO-LINK Module / SCALANCE XB005/ Communication board RS 485
- SIEMENS SENTRON Measuring Device, PAC1600, LCD, 1AC,230V, (Modbus RTU/ASCII, Apparent/ Active/Reactive Energy)
- SIEMENS HMI KTP700 CASE PANEL
- IFM RFID System IO-LINK (Reader & Antenna)
- IFM Proximity Sensors



Practice:

- Programmable Logic Controllers (PLCs) such as the SIEMENS SIMATIC S7-1200, which are used to control and monitor industrial processes
- IO-Link, a communication protocol for connecting sensors and actuators to PLCs and other automation equipment
- RFID technology, which is used to identify and track products and assets in industrial environments.

AA700.001.02/AA700.002.02/AA700.003.02/AA700.004.02

SMART FLEXIBLE ASSEMBLY TRAINING SYSTEM

Description:

The Smart Flexible Assembly Training System comprises of five stations with five conveyor belts linked together precisely at the same height to ensure a smooth path for the pallets that will flow through. A fully automated pneumatic warehouse station with a 6-workpiece capacity provides rigorous PLC controlled horizontal linear positioning of the workpieces with feedback ensured by two sensors (capacitive and inductive). Each of the conveyors are powered by different types of electric motors: AC or DC motors, synchronous or asynchronous motors, brush motor. For rigorous positioning, encoder disks with counters monitor the direction and speed of each conveyor providing valuable feedback to the PLC controller unit.

- AA700.001.02 - ABB IRB-1100, OmniCore Compact controller, PN
- AA700.002.02 - MITSUBISHI RV-2FR, CR800 controller, PN
- AA700.003.02 - Universal Robots UR3e controller PN_IFM Vision Control 3D
- AA700.004.02 – ABB CRB 1100, Compact Controller, PN

The structure includes (main pieces):

- 5x AA200.000.02 Workstation MR (800 x 800 x750) with Modular Supply Panel
- 1x AA054.200.02 - SIMATIC IoT2050 Training Panel SIEMENS
- 1x AA048.010.07 PLC S7-1513 TRAINING PANEL (CPU1513-1PN)
- 2x AA044.000.07 PLC S7-1215C TRAINING PANEL (CPU1215C COMPACT)
- 1x AA071.001.04 HMI MTP1500 UNIFIED COMFORT TRAINING CASE with Flexible Support
- 3x AA094.101.20 CONVEYOR TOOTHED BELT WITH SERVOMOTOR (S200/1FL2)
- 1x AA094.101.04 CONVEYOR TOOTHED BELT with Asynchronous 3xAC Motor
- 3x AA047.000.01 SINAMICS S200 Training Panel
- 1x AA042.000.03 SINAMICS G120 PN TRAINING PANEL (1xAC,230V, 0.37kW)
- 1x AA026.001.03 HMI KTP700 TRAINING CASE with Flexible Support
- AA059.000.09 AIR Compressor SUPERSILENT & AA059.000.06 Regulator FILTER
- AA096.001.04 Double GRIPPER E-PNEUM VACUUM (SMC)
- AA096.001.05 CAGE FOR TRAINING ROBOT (safety for ROBOT- non for UR3E & ABB CRB 1100)
- AA095.000.01 Compact Pneumatic Pallet Storage Unit
- AA095.000.02 - Compact Pneumatic Base Storage Unit
- AA095.000.05 Compact Pneumatic INDEX Unit
- AA095.000.04 Compact PRESS PIECES
- AA095.000.03 Compact Pneumatic TOP Storage
- AA095.000.06 Compact Pneumatic Assembled Pieces Storage Unit

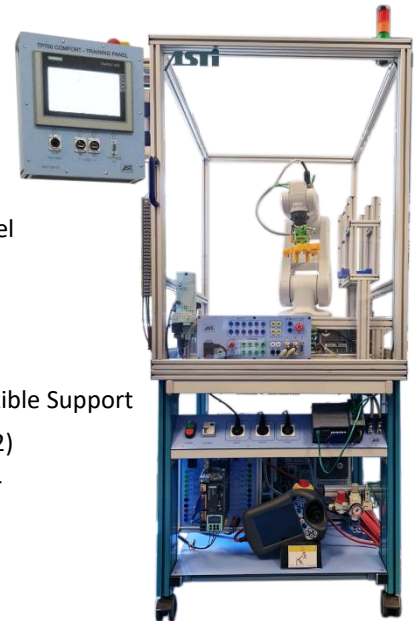

Practice:

- 3D product assembly with 6 axis industrial robot
- Controlling the process using S7-1200 & HMI MTP700
- Familiarize with the operating different types of motors
- Familiarize with various industrial communication
- Familiarize with the common components and concepts of SCADA systems

AA700.101.02 SMART CYBER-PHYSICAL SYSTEM ASSEMBLY LINE (AXIS) UR3 ROBOT

Description:

The SMART CYBER-PHYSICAL SYSTEM ASSEMBLY LINE is an automated production system designed to assemble products with 3D-printed components. It consists of five modular Cyber-Physical Systems (CPS), each connected by pneumatic transfer units that enable seamless movement of workpieces along the line. Each CPS module is equipped with a linear axis for transporting the working object and an RFID antenna for reading and writing data at each stage of the assembly process. The system is controlled through integrated PLC and HMI units in each module, providing both control and user interface functionality.

The line is designed to assemble a product consisting of a 3D-printed container, internal parts stored in two columns, and a cap. The assembly begins with the first CPS module, which contains a storage unit for containers. This module feeds containers into the assembly line and writes the assembly date onto the RFID tag attached to each container. The second CPS module is responsible for adding internal parts to the product. It reads the information from the RFID tag to determine the correct parts to add and integrates them into the assembled product. In the third CPS module, a storage and sorting unit handles caps that come in three different colors. The system selects the appropriate cap based on the information from the RFID tag and attaches it to the assembled product. The fourth CPS module includes a camera system that inspects the assembled product. It checks whether the product meets the specified criteria, and if any discrepancies are detected, the product is rejected. The final CPS module is equipped with a collaborative robot (UR3e) that places the completed product into a storage unit.

This assembly line enables a streamlined and automated assembly process for products with customizable components, ensuring efficient production and quality control.

The structure includes (main pieces):

- 5x CPS units with:
 - 1x Festo linear axis 500mm
 - 1x Siemens servo-motor
 - 1x Siemens servo-drive
 - 1x Siemens PLC S7-1500
 - 1x Siemens HMI KTP700
- 1x Container storage unit
- 1x Internal pieces storage unit
- 1x Cap storage unit
- 1x Cap sorting station with:
 - 1x Festo linear axis 500mm
 - 1x Festo linear axis 300mm
 - 1x Siemens servomotor 0.4kW
 - 1x Siemens servomotor 0.1 kW
 - 2x Siemens servodrives
- 1x IFM camera system for quality check
- 1x Universal Robot UR3e



Practice:

- 3D product assembly with 6 axis industrial collaborative robot
- Controlling the process using Siemens PLC and HMI
- Drive parametrization
- Industrial communication
- Familiarize with the operating different types of motors
- Familiarize with various industrial communication protocols and common components and concepts of SCADA systems

AA700.111.16/ AA700.112.16/AA700.113.16/ AA700.114.16

SMART FLEXIBLE ASSEMBLY LINE WITH CPS TRAINERS

Description:

The Smart Flexible WITH CPS (CYBER PHYSICALSYSTEM) ASSEMBLY TRAINING LINE comprises of three stations with three conveyor belts linked together precisely at the same height to ensure a smooth path for the pallets that will flow through. A fully automated pneumatic warehouse station with a 6-workpiece capacity provides rigorous PLC controlled horizontal linear positioning of the workpieces with feedback ensured by inductive sensors. Each of the conveyors is powered generally by different types of electric motors: AC or DC motors, synchronous or asynchronous motors, brush motor. For rigorous positioning, encoder disks with counters monitor the direction and speed of each conveyor providing valuable feedback to the PLC controller unit.

- AA700.111.16 - ABB IRB-1100, OmniCore Compact controller, PN
- AA700.112.16 - MITSUBISHI RV-2FR, CR800 controller, PN
- AA700.113.16 - UNIVERSAL ROBOT UR3E controller PN_IFM Vision Control 3D
- AA700.114.16 - ABB CRB 1100, Compact Controller, PN

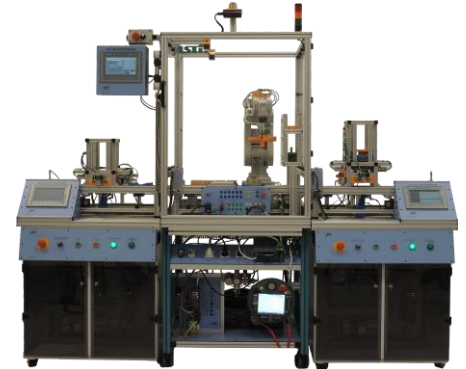

The structure includes (main pieces):

STATION 1 CPS PRE-ASSEMBLY STATION

- 1x AA100.101.20 CYBER PHYSICAL SYSTEM (**S200/1FL2 ServoMotor**)
- 1x AA095.000.01 COMPACT PNEUMATIC Pallet Storage UNIT

STATION 2 ROBOT ASSEMBLY STATION

- 1 x 6 AXIS ROBOTIC CELL (depend on the selected ordering code)
 - AA096.001.01 - ABB IRB-1100, OmniCore Compact controller, PN
 - AA096.002.01 - MITSUBISHI RV-2FR, CR800 controller, PN
 - AA096.003.01 –UNIVERSAL ROBOT UR3E controller PN_IFM VISION CONTROL 3D
 - AA096.004.01 - ABB CRB 1100, Compact Controller,PN

Each Station2 include also:

1x AA059.000.09 AIR COMPRESSOR SUPERSILENT

1x AA059.000.06 AIR SUPPLY FILTER REGULATOR

1x 6 AA095.100.01 3D PRINTED PIECES (SET with IFM RFID tag)

STATION 3 CPS STORAGE UNIT STATION

- 1x AA100.101.20 CYBER PHYSICAL SYSTEM (**S200/1FL2 ServoMotor**)
- 1x AA095.000.06 COMPACT PNEUMATIC Assembled Piece Storage Unit

STATION SYSTEM COMPUTING (MES)

- 1xAA701.111.16 MES (Manufacturing Execution System) SOFTWARE PACKAGE
- 1xAA600.103.01 Computer System with LICENSE and Display Monitor

Practice:

- 3D product assembly with 6 axis industrial robot
- Controlling the process using S7-1200 & HMI KTP700
- Familiarize with the operating different types of motors
- Familiarize with various industrial communication protocols and common components and concepts of SCADA systems

AA701.101.02/ AA701.110.16 MES SOFTWARE PACKAGE

Description:

The MES SOFTWARE Package for SMART CYBER-PHYSICAL System Assembly Line/ MES SOFTWARE Package for ADVANCED TRAINER CYBER-PHYSICAL System is a comprehensive solution designed to optimize and streamline the operations of didactic equipment simulating an industrial assembly line. This advanced software integrates cutting-edge technologies to enhance productivity, quality, and efficiency in manufacturing processes.

- AA701.101.02 MES SOFTWARE Package for **SMART CYBER-PHYSICAL System Assembly Line (AA700.101.02)**
- AA701.11X.16 MES SOFTWARE Package for **ADVANCED TRAINER CYBER-PHYSICAL System(AA700.11X.16)**

The structure includes (main features):

Real-Time Data Integration:

- Seamlessly integrates with IoT devices, sensors and other industrial equipment to collect and analyze real-time data
- Provides instant visibility into production processes, enabling quick decision making and proactive issue resolution

Quality Management:

- Captures and analyzes quality data throughout the production process, ensuring compliance with industry standards and reducing the risk of defects
- Provides traceability and audit trails for all production activities, facilitating regulatory compliance and quality improvement

Flexible and Scalable Architecture:

- Scalable to accommodate the growth of the assembly line, ensuring long-term viability and return on investment
- Supports both cloud-based and on-premises deployments, offering flexibility to adapt to various manufacturing environments

User-Friendly Interface:

- Features an intuitive and customizable dashboard that provides operators and managers with easy access to critical information
- Enhances user experience and reduces the learning curve, promoting efficient use of software

Open-Source Software:

- Leverages open-source software components, ensuring cost-effectiveness and flexibility
- Encourages community collaboration and continuous improvement, keeping the system up-to-date with the latest advancements

AA800.001.01 SMART SENSORS & COMMUNICATIONS TRAINING SYSTEM (IFM)

Description:

The IFM "SENSORS & COMMUNICATIONS" TRAINING SYSTEM is a comprehensive and versatile training solution for professionals in the industrial automation field. It includes a wide range of advanced equipment and components, such as a table-top stand with supply panel, PLC S7-1200 training panel, HMI training panel, Sinamics training panel, IFM AS-i AC402S training panel, conveyor belt with servo drive, and a set of IFM sensors and communications equipment.

The system includes a wide range of sensor types, including sensors with IO-Link, RFID evaluation units, pressure sensors, temperature transmitters, photoelectric distance sensors, and more. Additionally, the system includes advanced communications equipment such as IO-Link master with PROFINET interface, AS-Interface ClassicLine Module and RFID read/write antenna. The system also includes 3D printed pieces and an illuminated E-STOP with integrated AS-I. All these components are designed to provide hands-on training for professionals in the field of industrial automation.

The structure includes (main pieces):

- AA200.000.05 TABLE_TOP STAND with Supply Panel (850 x 760) mm
- AA044.000.03 PLC S7-1215C Training Panel Compact (CPU1215C 8DI 8DO 2AI 2AO)
- SWITCH SCALANCE XB005
- AA026.000.03 KTP700 HMI TRAINING PANEL
- AA060.000.02 IFM AS-I AC402S TRAINING PANEL
- AA094.101.20 CONVEYOR TOOTHED BELT WITH SYNCHRONOUS SERVO (S200_1FL2)
- AA047.000.01 SINAMICS S200 PANEL (1AC 240 V, 0.4KW)
- AA095.100.01 3D printed piece (1 set)
- A059.000.09 AIR Compressor SUPERSILENT
- Inductive sensor with IO-Link
- 5-segment light tower IO-Link programmable
- RFID evaluation unit with IO-Link, M12 connectors
- RFID read/write antenna with AS-Interface and RFID tag
- AS-Interface flat cable connector M12
- Illuminated E-STOP with integrated AS-I
- AS-Interface illuminated pushbutton module with 2 buttons
- AS-Interface Airbox 4 Digital Inputs and 2 Pneumatic Outputs
- Pressure sensor with IO-Link communication
- Temperature transmitter with display IO-Link and RFID read/write antenna IO-Link
- IO-Link master with PROFINET interface and AS-Interface Classic Line Module with 2 IO-LINK PORTS
- Photoelectric distance sensor with AS-Interface and AS-Interface Classic Line Module



Practice:

- Programmable Logic Controllers (PLCs) such as the S7-1200 and the AC402S
- Human Machine Interface (HMI) panels, which are used to interface with PLCs and other automation equipment
- AS-Interface, a communication protocol for connecting sensors and actuators to PLCs and other automation equipment
- IO-Link, a communication protocol for connecting sensors and actuators to PLCs and other automation equipment
- RFID technology, which is used to identify and track products and assets in industrial environments

Optional equipment:

- AA600.103.01 - PROSIM V+ ALL IN ONE PC 23.8" i5 TOUCH
- AA054.200.02 - SIMATIC IoT2050 Training Panel SIEMENS

AA800.002.01/AA800.002.02 INDUSTRIAL DETECTION OBJECTS SENSORS TRAINING SET (IFM)

Description:

The Industrial Detection Objects Sensors set is designed for object detection in various industrial applications. It includes a magnetic sensor that identifies magnetic fields and is suitable for detecting the proximity of magnetic objects. An inductive sensor is included for non-contact detection of metallic objects. The capacitive sensor in the set is capable of detecting both metallic and non-metallic objects.

Additionally, the set features two types of photoelectric sensors: a retro-reflective sensor that detects objects by reflecting light off a reflector positioned behind the target, and a diffuse reflection sensor, which detects objects by sensing the light reflected directly from the object itself. This combination of sensors provides comprehensive solutions for object detection in a variety of industrial settings.

In addition to the basic sensor set, an advanced version of the equipment includes integrated IO-Link technology for enhanced communication and data exchange. This version comes with an IO-Link master, which acts as the central interface for connecting and managing multiple sensors. The advanced sensor lineup includes an inductive analogue sensor with IO-Link for precise metal object detection and measurement, and a photoelectric distance sensor with IO-Link that provides accurate distance measurement based on light reflection. Also featured is a diffuse reflection sensor with background suppression and IO-Link, allowing for reliable detection of objects while ignoring background interference. A temperature sensor with a display and IO-Link is included for real-time monitoring. Lastly, the set includes an ultrasonic sensor with IO-Link, ideal for detecting objects and measuring distances in a wide range of industrial applications, including those involving liquids and non-reflective materials. This advanced setup offers improved diagnostics, configurability, and efficiency for complex detection tasks.

The structure includes (main pieces):

Industrial detection objects sensors (AA800.002.01):

- Magnetic sensor
- Inductive sensor
- Capacitive sensor
- Photoelectric sensor retro-reflective sensor
- Photoelectric sensor diffuse reflection sensor
- Aluminum frame

Industrial smart sensors training equipment (AA800.002.02):

- IO-Link master
- Inductive analogue sensor with IO-Link
- Photoelectric distance sensor with IO-Link
- Diffuse reflection sensor with background suppression with IO-Link
- Temperature sensor with display with IO-Link
- Ultrasonic sensor with IO-Link

Practice:

- Types of sensors: magnetic, inductive, optical, and capacitive detection methods
- Evaluating and selecting the right sensor for particular tasks or systems
- Key principles of wiring and circuit configurations
- Integration of different sensors in industrial application
- IO-Link sensors configuration

Optional equipment:

- AA048.001.05 – PLC-S7-1512C Training Panel
- AA054.200.02 - SIMATIC IOT2050 TRAINING PANEL SIEMENS

AA900.010.01 SMART PROCESS CONTROL LEARNING SYSTEM

Description:

The Process Control Learning System (BPCLS) is a comprehensive training system that covers industrial-standard applications for open-loop and closed-loop control of level, flow, pressure, and temperature processes. It is designed to provide an enhanced learning experience for process control, and to speed up the training process in a safe, controlled environment with minimal risk. The BPCLS leverages the basic input/output (IO) and programming capabilities of a Programmable Logic Controller (PLC) with the Siemens S7-1200 automation configuration, as well as the basic graphic assets of the Siemens HMI KTP700. This allows users to acquire hands-on experience with the calibration, operation, and troubleshooting of industrial equipment such as pumps, flow-level-pressure-temperature transducers, and inverters.

The structure includes (main pieces):

- 1x AA087.000.02 - Coupled Tank System ASTANK-2+ (L, F, P, T)
- 1x AA087.011.02 - PLC S7-1215 (CPU1215C) Training Panel ASTANK-2+
- 1x AA026.000.03 – HMI KTP700 Training Panel
- 1x AA087.100.01 - ASTANK-2+ Software Package (SIEMENS PLC)
- 1x AA200.000.05 - Table-Top Stand for Training Panels with Modular Supply Panel

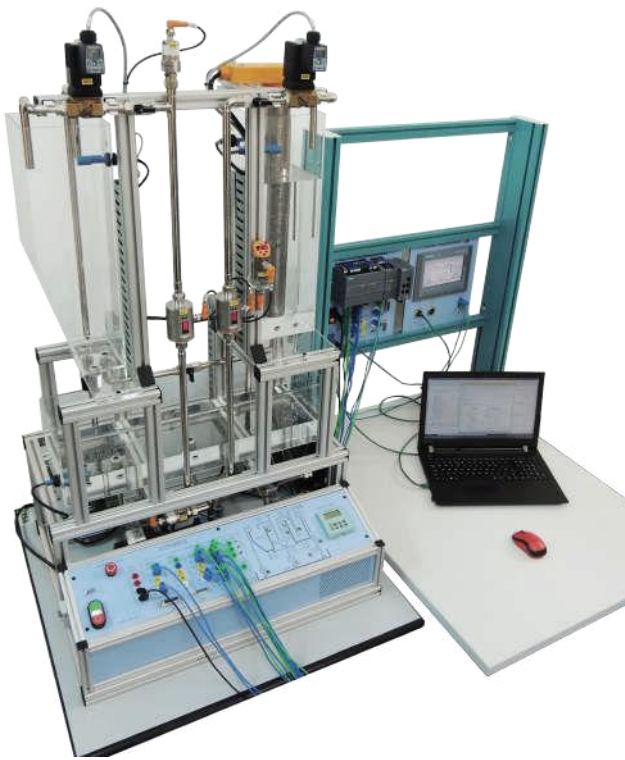

The system includes demo software for basic commissioning, PI level control, PID temperature control, and non-linear control. These features accelerate the learning curve for developing process control PLC programs in a realistic training environment. The BPCLS is an ideal solution for individuals and organizations that want to improve their process control skills and gain a deeper understanding of industrial equipment and processes.

Moreover, BPCLS is designed to mimic real-world scenarios as closely as possible, allowing users to gain hands-on experience in a safe and controlled environment. This reduces the risk of errors and accidents that may occur during training with real equipment. The BPCLS is a cost-effective and efficient way to improve process control skills, and it can be used in a variety of settings, including academic institutions, training centers, and industrial plants.

The BPCLS is also highly customizable, allowing users to adjust the system to suit their specific training needs. This includes the ability to set custom parameters and conditions, as well as the ability to create and edit custom control algorithms. This level of

customization allows users to tailor the training experience to their individual needs, and to focus on the areas where they need the most improvement.

Overall, the Process Control Learning System (BPCLS) is a powerful tool for improving process control skills and gaining a deeper understanding of industrial equipment and processes. It offers an enhanced learning experience through hands-on training, educational resources and materials, and a high degree of customizability. It is an ideal solution for individuals and organizations looking to improve their process control skills and increase their efficiency in the industrial setting.

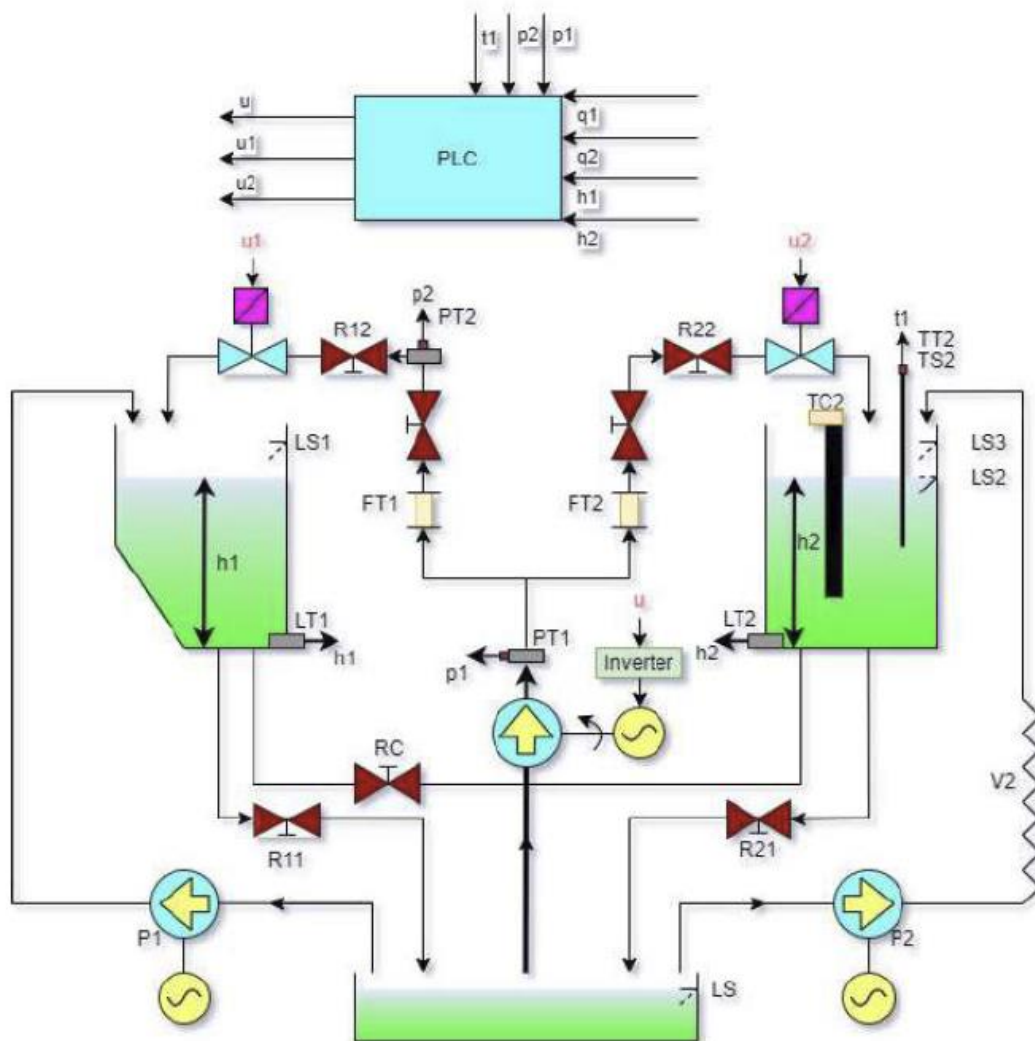

Practice:

- Data acquisition for analytic modelling and/or experimental identification of the processes
- Design of simple control structures (single controller of type P, PI or PID), design of multi-model control algorithms or for multi-variable processes
- Implementation of adaptive structures for time-variant processes
- Implementation of control strategies based on evolutionary techniques (fuzzy controllers, genetic algorithms, neural networks)
- Basic PLC and HMI programming

Optional equipment:

- AA600.103.01 - PROSIM V+ ALL IN ONE PC 23.8" i5 TOUCH
- AA600.102.01 - PROSIM V+ 10.5-inch Tablet Display

AA900.010.03 (CONTROLLER AA900.010.13) SMART PROCESS CONTROL LEARNING SYSTEM

Description:

The SMART PROCESS CONTROL LEARNING SYSTEM is a state-of-the-art industrial control system designed for open / close loop control of an industrial fan. It utilizes cutting-edge technology such as a laser sensor for distance measurement and an advanced asynchronous motor for powerful airflow of 900 m³. The system is constructed with a durable aluminum frame and features advanced control and monitoring features like a SINAMICS V20, as well as various switches and potentiometers for local control. The system is easy to integrate with other equipment and can be controlled remotely, providing a smart and efficient way to manage the performance of an air fan, resulting in improved process control and energy savings.

Furthermore, the system is a highly customizable and flexible solution, allowing users to configure the system to their specific needs. The system can be programmed to operate within a specific set of parameters and can be fine-tuned to ensure optimal performance. This level of control and precision can lead to significant cost savings and improved production efficiency. Additionally, the system comes with a user-friendly interface that makes it easy to monitor and adjust settings, even for those with limited technical experience. Overall, the system is an innovative and reliable solution for managing the performance of an air fan, providing industrial facilities with improved process control, energy savings and increased production efficiency.

The SMART PROCESS CONTROL LEARNING SYSTEM offers multiple control options. It features manual control through the PLC, allowing users to operate the system directly. It also supports automatic control via the PLC, which runs based on preset parameters. Additionally, the system can be remotely controlled through Matlab/Simulink, enabling users to program, monitor, control and adjust settings from a PC. These control options make the system adaptable for a variety of applications, from simple manual tasks to more complex automated operations.

The structure includes (main pieces):

- 1x PLC S7-1215C Siemens PLC
- 1x Asynchronous motor, 0.37kW, 2800 rpm, 230 VAC
- 1x Fan maximum air flow: 900 m³/h, maximum pressure: 420 Pa
- 1x Laser sensor for measuring distance (0 – 2M)
- 1x MTP700 Unified Comfort Siemens
- Aluminum Profile (30x30) Frame
- Electric box with:
 - 1x SINAMICS V20 200-240 V 1-phase-AC Rated power 0.37 kW I/O interface: 4 DI, 2 DQ, 2 AI, 1 AO
Fieldbus: USS/Modbus RTU with built-in BOP
 - 1x Switch for control selection
 - 2x Ethernet ports
 - 2x USB ports



Practice:

- Data acquisition for experimental identification of the processes
- Design of simple control structures (single controller of type P, PI or PID), design of multi-model control algorithms
- Implementation of adaptive structures for time-variant processes
- Implementation of control strategies based on evolutionary techniques (fuzzy controllers, genetic algorithms, neural networks)
- Basic PLC and HMI programming

Optional equipment:

- AA054.200.02 - SIMATIC IoT2050 Training Panel SIEMENS

AA900.010.05 (CONTROLLER AA900.010.15) SMART PROCESS CONTROL LEARNING SYSTEM

Description:

The SMART PROCESS CONTROL LEARNING SYSTEM is an advanced, customizable industrial control platform, perfect for open and closed loop control of dual industrial fans. Equipped with two laser sensors featuring IO-Link communication for precise distance measurement, the system integrates cutting-edge components like the S7-1200 Siemens PLC and the MTP700 Unified Siemens HMI for superior process control. An IFM IO-Link Master manages IO-Link connectivity, while two asynchronous motors provide powerful airflow, controlled by Siemens V20 frequency inverters. This system is highly adaptable, allowing users to configure parameters for tailored performance, and is easily programmable for optimal operation. Its user-friendly interface ensures simple monitoring and adjustments, making it suitable for users with varying levels of technical expertise. Ideal for educational or industrial training applications, this system is a robust tool for learning and mastering modern process control technologies. The SMART PROCESS CONTROL LEARNING SYSTEM offers multiple control options. It features manual control through the PLC, allowing users to operate the system directly. It also supports automatic control via the PLC, which runs based on preset parameters. Additionally, the system can be remotely controlled through Matlab/Simulink, enabling users to program, monitor, control and adjust settings from a PC. These control options make the system adaptable for a variety of applications, from simple manual tasks to more complex automated operations.

The structure includes (main pieces):

- 1x PLC S7-1215C Siemens PLC
- 2x Asynchronous motor, 0.37kW, 2800 rpm, 230 VAC
- 2x Fan maximum air flow: 900 m³/h, maximum pressure: 420 Pa
- 2x Laser sensor for measuring distance (0 – 2M)
- 1x MTP700 Unified Siemens
- Aluminum Profile (30x30) Frame
- Electric box with:
 - 2x SINAMICS V20 200-240 V 1-phase-AC Rated power 0.37 kW I/O interface: 4 DI, 2 DQ, 2 AI, 1 AO
Fieldbus: USS/Modbus RTU with built-in BOP
 - 2x Switches for control selection
 - 1x Ethernet ports
 - 1x USB ports



Practice:

- Data acquisition for experimental identification of the processes
- Design of simple control structures (single controller of type P, PI or PID), design of multi-model control algorithms
- Implementation of adaptive structures for time-variant processes
- Implementation of control strategies based on evolutionary techniques (fuzzy controllers, genetic algorithms, neural networks)
- Basic PLC and HMI programming

Optional equipment:

- AA054.200.02 - SIMATIC IoT2050 Training Panel SIEMENS

AA900.020.01/AA900.020.02/AA900.020.03 SMART PLC PROGRAMMING LEARNING SYSTEM

Description:

The Smart PLC programming system is built around an industrial process simulator (PROSIM V+) for immersive and engaging virtual learning experiences in industrial automation training, research, and development. It offers a complete software package (39 scenarios) for discrete and continuous automation processes in various fields of industry. The simulated process list, in increasing order of complexity, covers rich 2D/3D graphics and animations running on small or large capacitive displays. The Siemens S7-1200 PLC includes industrial standardized 14DI/10DO/2AI/2AO IO interface and PROFINET connection for programming and data linking. The solution includes 39 demo projects.

The structure includes (main pieces):

- AA900.020.01 includes: 1xAA044.002.02 - PLC S7-1212C Training Panel (CPU1212C) SIEMENS
- AA900.020.02 includes: 1xAA044.001.05 – PLC S7-1214C Training Panel (CPU1214C) SIEMENS
- AA900.020.03 includes: 1xAA044.001.02 - PLC S7-1215C Training Panel (CPU1215C) SIEMENS
- 1x AA600.101.04 - PROSIM V+ Smart Digital Coupler
- 1x AA600.103.01 - PROSIM V+ ALL IN ONE PC 23.8" i5 TOUCH
- 1x AA200.000.05 - Table-Top Stand for Training Panels with Modular Supply Panel

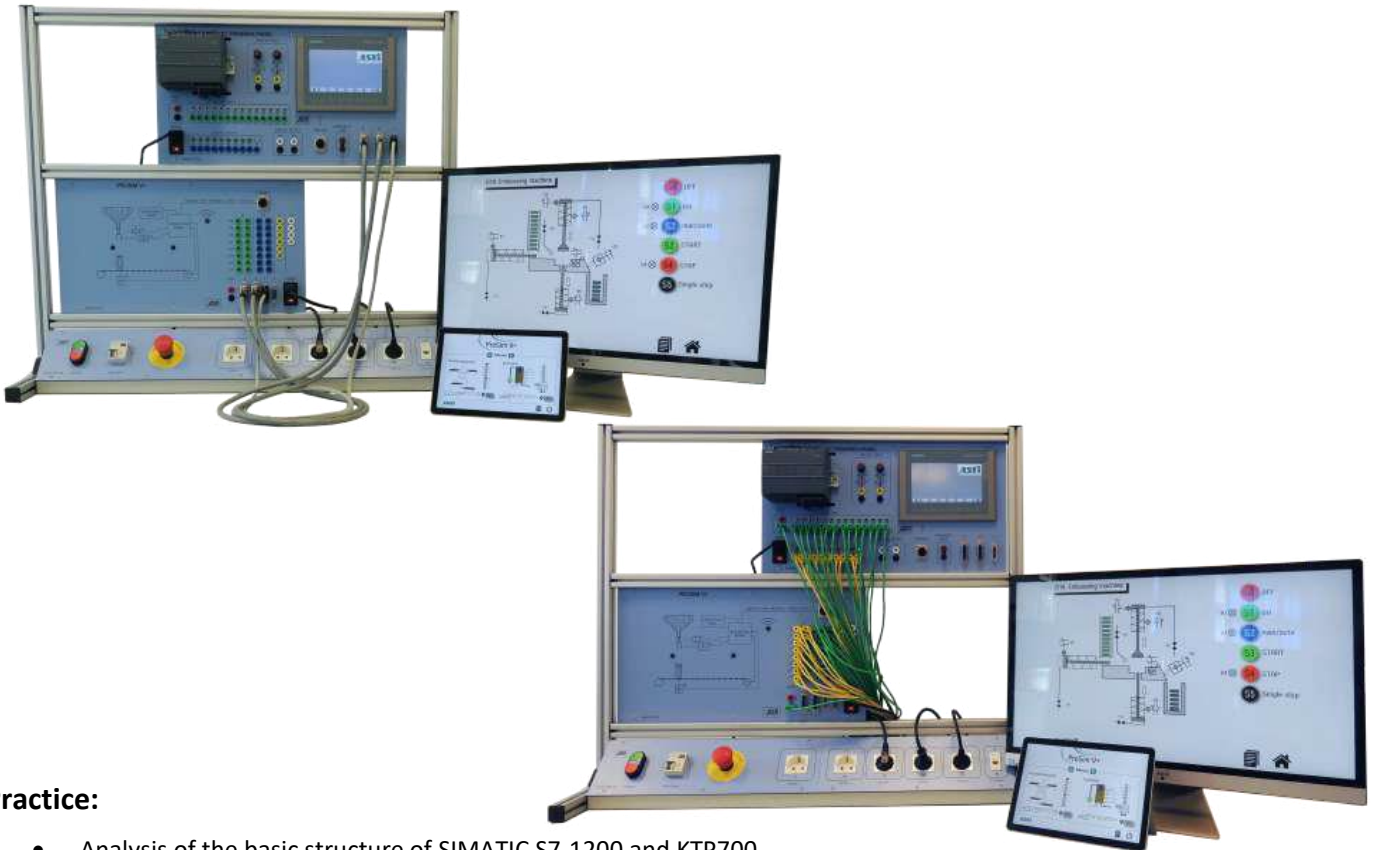

Practice:

- Analysis of the basic structure of SIMATIC S7-1200 and KTP700
- Implementing programming languages in TIA Portal (LAD FBD, and SCL)
- Designing and implementing solutions for practical applications such as: motor controls, pumping systems, conveyor belts, lift control...etc.
- Study of the basic logic functions, numerical operations, and arithmetic instructions
- Integration of human machine interface in the automation process

Optional equipment:

- AA600.102.01 - PROSIM V+ 10.5-inch Tablet Display

AA900.020.12/ AA900.020.13/AA900.020.16/AA900.020.17

SMART PLC PROGRAMMING LEARNING SYSTEM

Description:

The Smart PLC Programming Learning System provides additional automation capabilities in comparison with the basic version by using the Siemens S7-1500 and optional MTP700 as a base for the control infrastructure. The automation topology assures future scalability with an advanced and easy to use graphical interface that includes reports, recipes and user defined programs that manage the process. The Siemens S7-1500 PLC includes industrial standardized 16DI/16DO/4AI/4AO IO interface and PROFINET/PROFIBUS connection for programming and data linking. The Siemens MTP700 provides advanced graphic capabilities. The solution includes one demo project for each simulation.

The structure includes (main pieces):

- AA900.020.12 includes: 1x AA048.001.05 - PLC S7-1500 Training Panel (CPU1512C-1PN)
- AA900.020.13 includes: 1x AA048.001.07 - PLC S7-1500 Training Panel (CPU1513-1PN)
- AA900.020.16 includes: 1x AA048.001.03 - PLC S7-1500 Training Panel (CPU1516-3PN/DP)
- AA900.020.17 includes: 1x AA048.001.04 - PLC S7-1500 Training Panel (CPU1516F)
- 1x AA600.101.04 - PROSIM V+ Smart Digital Coupler
- 1x AA600.103.01 - PROSIM V+ ALL IN ONE PC 23.8" i5 TOUCH
- 1x AA200.000.05 - Table-Top Stand for Training Panels with Modular Supply Panel

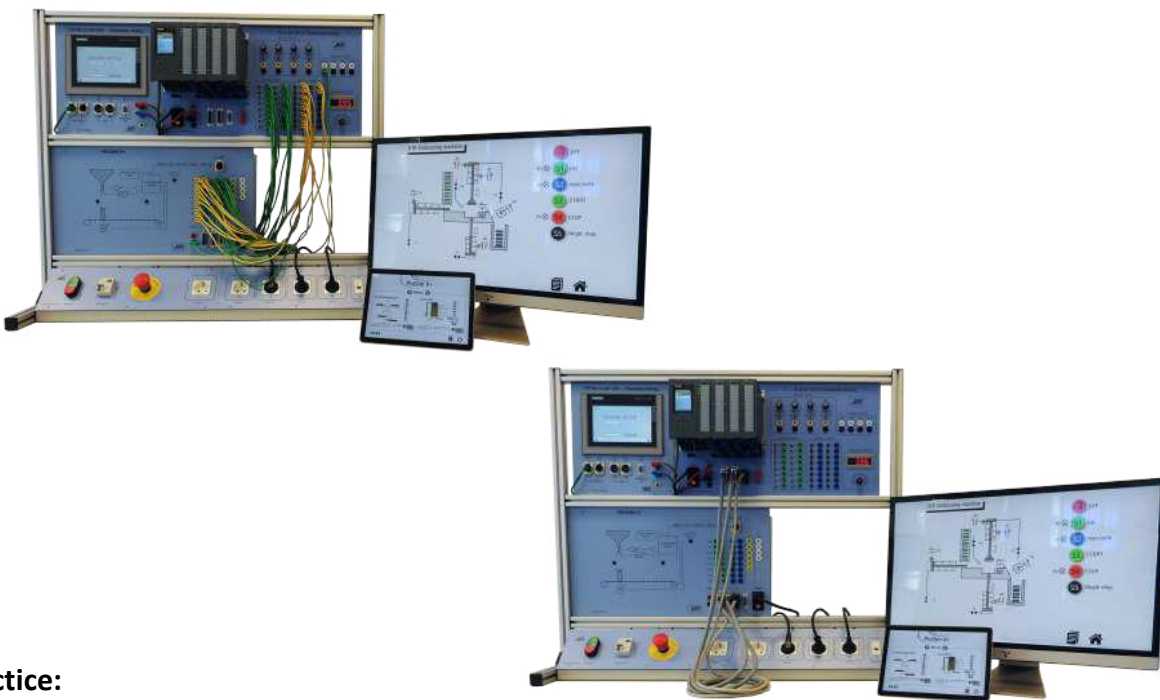

Practice:

- Analysis of the basic structure of Simatic S7-1500 and MTP700
- Implementing programming languages in TIA Portal (LAD, FBD, and SCL)
- Designing and implementing solutions for practical applications such as: motor controls, pumping systems, conveyor belts, lift control etc.
- Study of the basic logic functions, numerical operations, and arithmetic instructions
- Integration of human machine interface in the automation process

Optional equipment:

- AA071.000.05 - HMI MTP700 COMFORT TRAINING PANEL
- AA600.102.01 - PROSIM V+ 10.5-inch Tablet Display

AA900.025.12/ AA900.025.10/AA900.023.14 SMART PLC PROGRAMMING LEARNING SYSTEM

Description:

The Smart PLC Programming Learning System provides additional automation capabilities in comparison with the basic version by using the Siemens ET200SP and optional MTP700 as a base for the control infrastructure. The automation topology assures future scalability with an advanced and easy to use graphical interface that includes reports, recipes and user defined programs that manage the process. The Siemens ET200SP (1512SP, 1510SP) PLC includes industrial standardized 16DI/16DO/4AI/4AO IO interface and PROFINET/PROFIBUS connection for programming and data linking. The Siemens MTP700 provides advanced graphic capabilities. The solution includes one demo project for each simulation.

The structure includes (main pieces):

- AA900.025.12 includes: 1x AA062.001.02 – ET200SP (CPU 1512SP) Distributed Training Panel
- AA900.025.10 includes: 1x AA062.002.02 – ET200SP (CPU 1510SP) Distributed Training Panel
- AA900.023.14 includes: 1x AA061.001.03 – PLC S7-314C TRAINING PANEL (CPU 314C-2PN/DP)
- 1x AA600.101.03 - PROSIM V+ Smart Digital Coupler
- 1x AA600.103.01 - PROSIM V+ ALL IN ONE PC 23.8" i5 TOUCH
- 1x AA200.000.05 - Table-Top Stand for Training Panels with Modular Supply Panel



Practice:

- Analysis of the basic structure of Simatic S7-1500 and MTP700
- Implementing programming languages in TIA Portal (LAD, FBD, and SCL)
- Designing and implementing solutions for practical applications such as: motor controls, pumping systems, conveyor belts, lift control etc.
- Study of the basic logic functions, numerical operations, and arithmetic instructions
- Integration of human machine interface in the automation process

Optional equipment:

- AA071.000.05 - HMI MTP700 COMFORT TRAINING PANEL
- AA600.102.01 - PROSIM V+ 10.5-inch Tablet Display

AA900.030.01/AA900.030.02 SMART VIBRATION ANALYSIS LEARNING SYSTEM

Description:

The Smart Vibration Analysis Learning System and the Advanced Smart Vibration Analysis Learning System are both powerful solutions for monitoring and protecting machines during operation. They both incorporate highly valuable didactic topics that enable the measurement of specific variables for effective monitoring and maintenance of various manufacturing processes. The Smart Vibration Analysis Learning System provides a complete solution for vibration monitoring, conditional monitoring, and machine protection/process monitoring. It includes a powerful monitoring tool that can observe up to 24 objects and share information via Profinet. Mechanical vibration is of special significance in both systems as it is one of the most important measured variables for effectively describing the state of the machine.

The structure includes (main pieces)

- One of the following:
 - 1x AA031.010.05 - VALS IFM CONDITION MONITORING
 - 1x AA031.010.04 - VALS SIEMENS CONDITION MONITORING (S7-1281)
- 1x AA200.000.05 - Table-Top Stand for Training Panels with Modular Supply Panel
- 1x AA600.103.01 - PROSIM V+ ALL IN ONE PC 23.8" I5 TOUCH

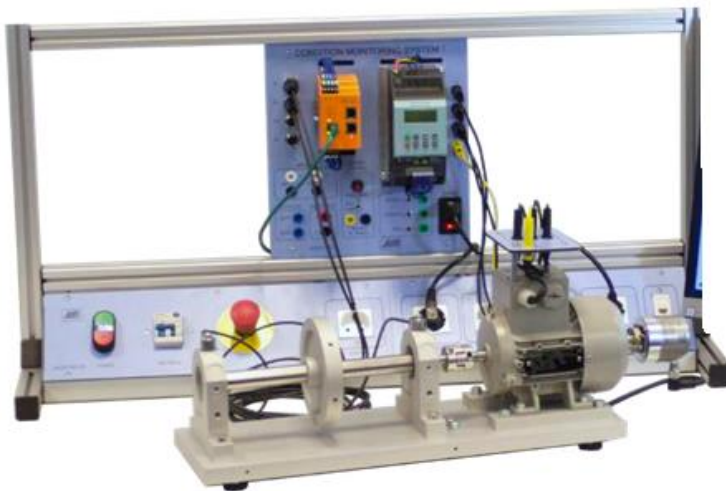

Practice:

- Characteristic values (bearing, vibration monitoring)
- Frequency-selective analysis using FFT, H-FFT
- Vibration monitoring (total vibration to ISO)
- Condition monitoring (condition-based monitoring based on vibration characteristics)
- Recording with time stamp of trend values, raw data, frequency spectra, alarm log
- Machine protection/process monitoring (monitoring vibration characteristics in real time with a fast reaction time up to 1ms)
- Recording with time stamp of trend values, raw data, frequency spectra, alarm log
- Simple localization of damage using fingerprint comparison
- Extraction of raw data for further diagnoses
- Monitoring objects within the time range (v-RMS, a-RMS, and a-Peak)

Optional equipment:

- AA600.103.01 - PROSIM V+ ALL IN ONE PC 23.8" I5 TOUCH

AA900.040.02

ADVANCED MOTION CONTROL LEARNING SYSTEM

Description:

The Advanced Smart Motion Control Learning System (ASMCLS) covers more advanced applications such as gearing and camming. The main unit is Siemens 1500T which allows the use of specific multi-axes synchronization via Profinet network, it provides standardized motion control functions in accordance with PLCopen regarding CPU Drive data linking and configuration. Typical applications vary between simple speed control and positioning loops, to more complex such as cam tracking and gearing. The system includes two 1FL2 servomotors each linked with S200 driver. Moreover, the Demo project allows the user to make a first step in motion control.

The structure includes (main pieces):

- 1x AA047.002.01 - MOTION CONTROL SINAMICS S200 TRAINING SYSTEM
- 1x AA071.000.02 - HMI MTP700 COMFORT TRAINING PANEL
- 1x AA200.000.05 - Table-Top Stand for Training Panels with Modular Supply Panel

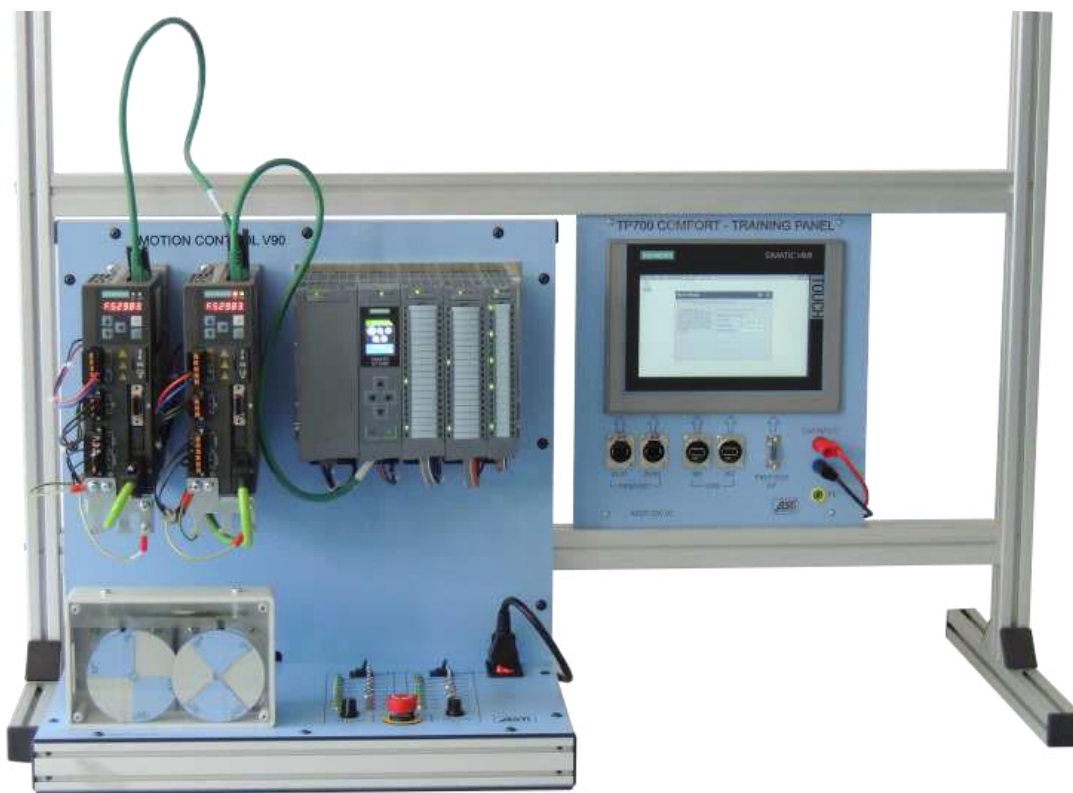

Practice:

- Speed-controlled loops
- Rotary positioning control loops
- Synchronized axes
- Cams
- Cam tracking
- Cam disk and Gearing
- User defined kinematics

Optional equipment:

AA600.103.01 - PROSIM V+ ALL IN ONE PC 23.8" i5 TOUCH

AA900.050.01 SMART ENERGY MANAGEMENT LEARNING SYSTEM

Description:

The Smart Energy Management Learning System (SEMLS) can display all the relevant system parameters in low-voltage power distribution. The main unit, Siemens Sentron PAC3220, is capable of single-phase, two-phase or three-phase measurement and can be used in two-wire, three-wire, four-wire, TN, TT and IT systems. It can be used for monitoring, diagnostics and service functions, a two-tariff active energy and reactive energy counter, a universal counter, and a working hours counter for monitoring the running time of connected loads. Relevant trends can be implemented on the MTP700 graphic interface, moreover energy consumption reports can be generated for future analysis. The measured data can be shared via the Modbus TCP/IP communication protocol.

The structure includes (main pieces):

- 1x AA088.100.01 - SENTRON PAC3220 Energy Measurement Training Panel
- 1x AA600.103.01 - PROSIM V+ ALL IN ONE PC 23.8" i7 (LENOVO)
- 1x AA055.000.01 - Power Supply
- 1x AA200.000.04 - TABLE-TOP STAND with MODULAR SUPPLY PANEL (3-PHASE) SIZE (WxH) 910x790 mm

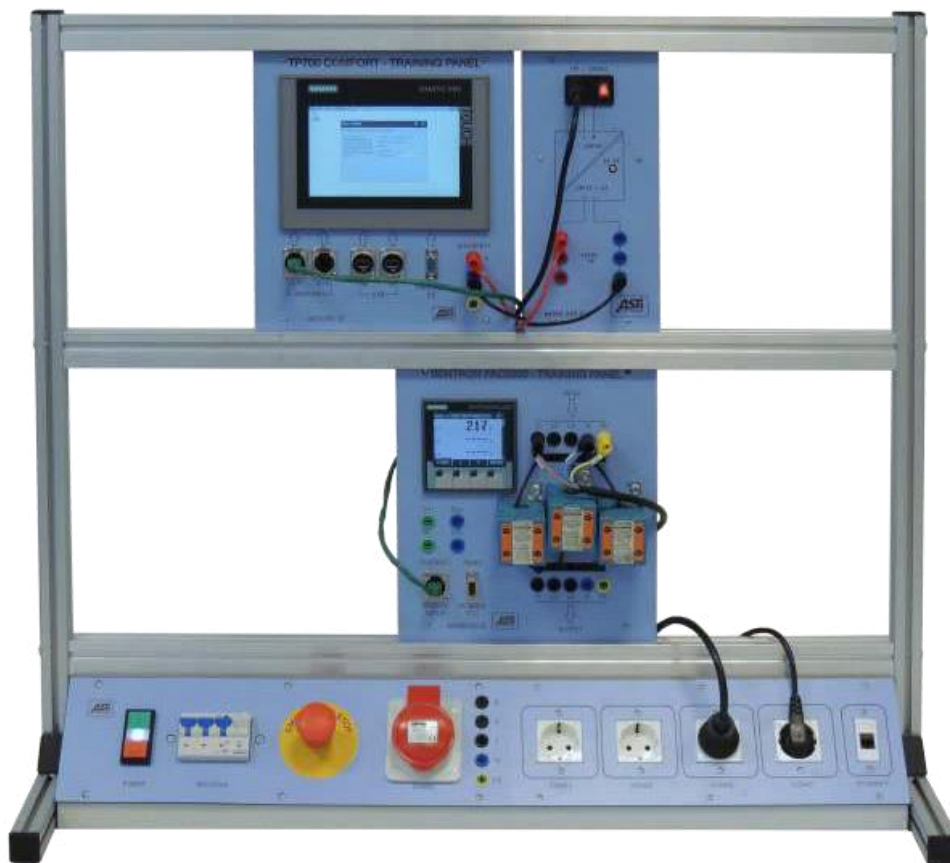

Practice:

- Basic metering
- Electrical Parameters monitoring voltage, current, active power, reactive power, apparent power, active energy, reactive energy, apparent energy, power factor, frequency, and distortion factor
- Modbus TCP/IP Topology
- Energy reports

Optional equipment:

- AA071.000.05 - HMI MTP700 COMFORT TRAINING PANEL

AA900.050.02 ADVANCED ENERGY MANAGEMENT LEARNING SYSTEM (CPU 1215C)

Description:

The Advanced Energy Management Learning System (AEMLS) is built around two modules of Siemens Simatic SM 1238 Energy Meter Module, each capable of measuring electrical variables from single-phase, two-phase, and three-phase power supply, maximum nominal voltage between two outer conductors 480 VAC (max. phase voltage 277 VAC). The system can determine energy consumption and power demand. Relevant trends can be implemented on the PC23 graphic interface, and energy consumption reports can be generated for future analysis.

The structure includes (main pieces):

- 1x AA089.001.02 - ENERGY METER Training Panel (CPU1215C, 6 channels)
- 1x AA089.100.02 - Sockets Panel
- 1x AA600.103.01 - PROSIM V+ALL IN ONE PC23.8" I5 TOUCH
- 1x AA200.000.04- Table Top Stand for training panels with Power Supply

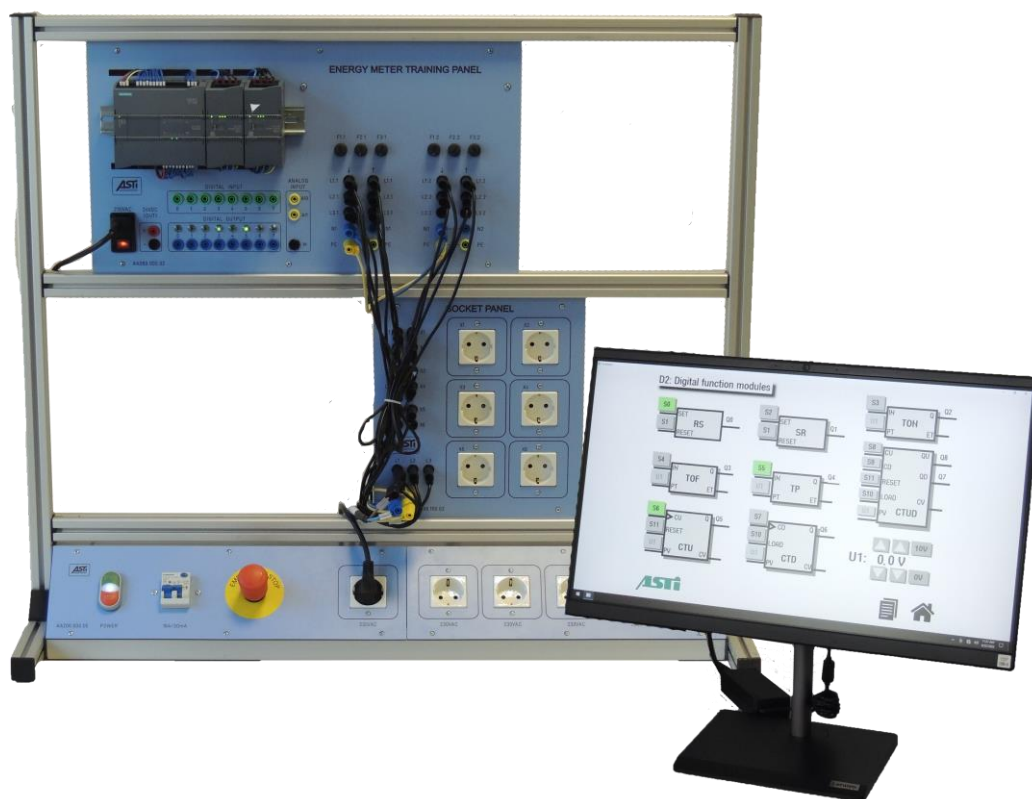

Practice:

- Energy metering
- Energy reports
- Comparative analysis for multi-point energy metering
- Identification of power peaks
- Recording of voltages, currents, phase angles, power (electrical load-active (W), reactive (var), apparent (VA)), energy usage counter (electrical work), frequencies, minimum and maximum values, power factors, operating hours counters

Optional equipment:

- AA071.001.06 - HMI TP1200 COMFORT TRAINING CASE with Flexible Support

AA900.050.03 ADVANCED ENERGY MANAGEMENT LEARNING SYSTEM (CPU 1510SP)

Description:

The Advanced Energy Management Learning System (AEMLS) is built around two modules of Siemens Simatic ET200SP (CPU 1510SP) AI ENERGY METER Module, each capable of measuring electrical variables from single-phase, two-phase, and three-phase power supply, maximum nominal voltage between two outer conductors 480 VAC (max. phase voltage 277 VAC). The system can determine energy consumption and power demand. Relevant trends can be implemented on the PC23 graphic interface, and energy consumption reports can be generated for future analysis.

The structure includes (main pieces):

- 1x AA089.002.02 - ENERGY METER PANEL (CPU 1510SP ,2x AI ENERGY METER)
- 1x AA089.100.02 - Sockets Panel
- 1x AA600.103.01 - PROSIM V+ ALL IN ONE PC 23.8" I5 TOUCH
- 1x AA200.000.04- Table Top Stand for training panels with Power Supply

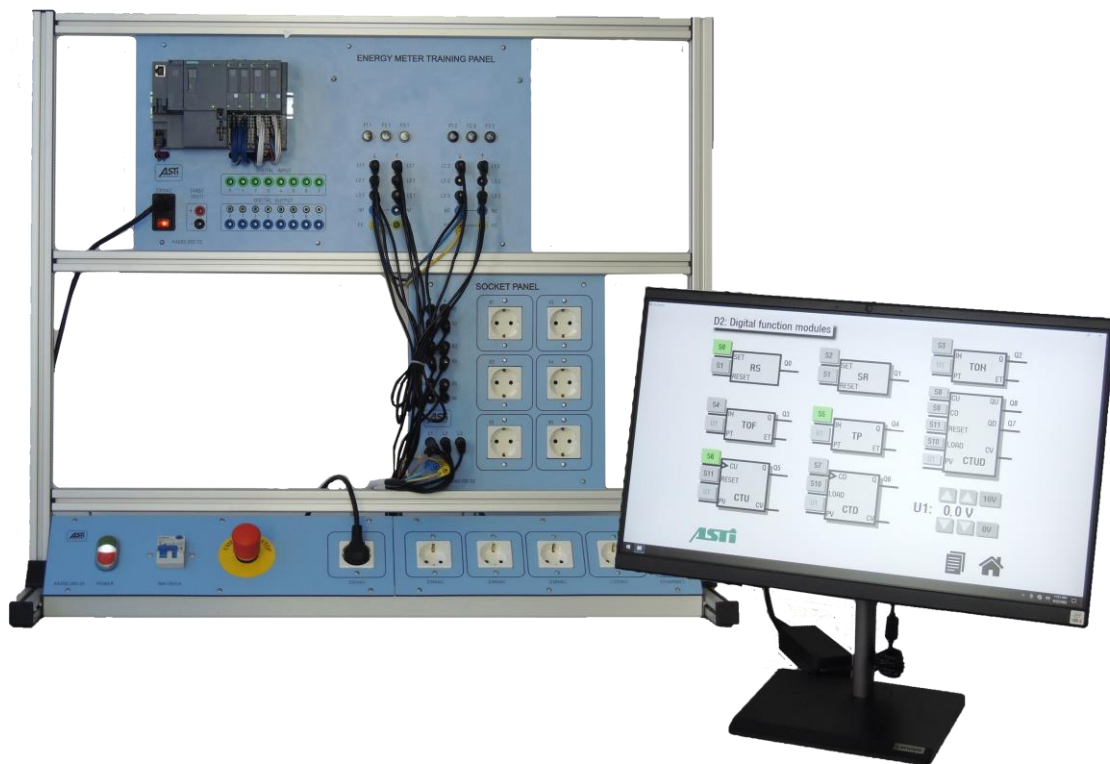

Practice:

- Energy metering
- Energy reports
- Comparative analysis for multi-point energy metering
- Identification of power peaks
- Recording of voltages, currents, phase angles, power (electrical load-active (W), reactive (var), apparent (VA)), energy usage counter (electrical work), frequencies, minimum and maximum values, power factors, operating hours counters

Optional equipment:

- AA071.001.06 - HMI TP1200 COMFORT TRAINING CASE with Flexible Support

AA900.060.01 INTELLIGENT ROBOTS AND MECHATRONICS LAB

Description:

The Intelligent Robots and Mechatronics Lab (IRML) is built around two industrial-standard conveyor units each powered by one 1FL6 servomotor. The closed-loop positioning control is assured by the new Siemens servo-drive S200. The motion synchronization is assured by the Siemens S7-1200 PLC via Profinet communication topology. Two robotic arms (with 4 DoF and electric gripper) are used to combine 3D printed sub-assemblies into one final product. Each robot is controlled by one OpenCR board, an open-source hardware/software platform, used for robot control.

The structure includes (main pieces):

- 2xAA094.101.20 - CONVEYOR TOOTHED BELT WITH SYNCHRONOUS SERVOMOTOR (S200/1FL2)
- 2xAA047.000.01 - SINAMICS S200 TRAINING PANEL (0.4 kW)
- 1xAA066.001.02 - PLC S7-1215C & HMI TRAINING PANEL (CPU 1215C, KTP700)
- 2xOpenManipulator with gripper and 4 DoF
- 2xROBOTIS OpenCR1.0 Dynamixel controller
- 1xAA200.000.05 - Table-Top Stand for Training Panels with Modular Supply Panel

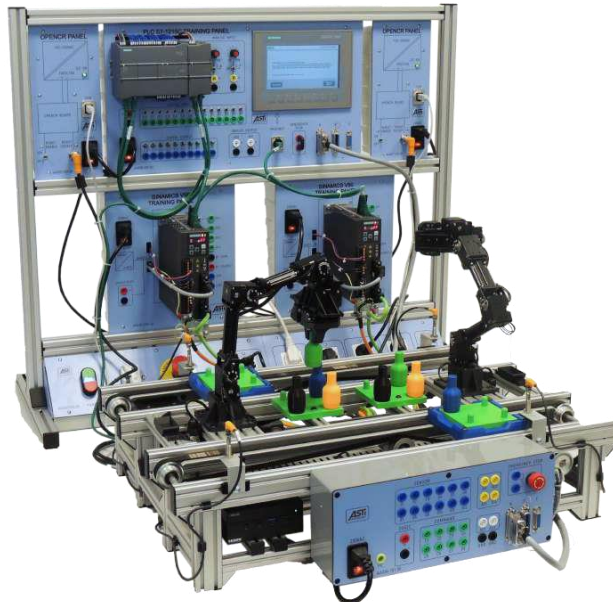

Practice:

- Robot programming using an open hardware and software platform
- Compact open-source robot based on ROS
- OpenCR1.0 is developed for ROS embedded systems to provide completely open-source hardware and software.
- 3D product assembly with 2 robot arms
- Principle and function of various industrial sensors and actuators
- Making controlled movement on two conveyors and synchronization with two robot arms
- Controlling the systems using Siemens PLC-S7-1200 & KTP700 HMI
- Controlling the Servo motors of conveyors using SINAMICS S200 servo Drives
- Using 1FL6 servomotors work with conveyor belt for high precision positioning
- Positioning of a work piece carrier

Optional equipment:

- AA600.103.01 - PROSIM V+ ALL IN ONE PC 23.8" i5 TOUCH

AA900.060.03 INTELLIGENT MOBILE ROBOT PLATFORM

Description:

The Intelligent Mobile Robot Platform (IMRP) is a didactic robotic system which consists of two teaching robots (Robotino 4®, Niryo Ned®) and sensors. The system can be used in current industry issues such as handling and moving objects.

The IMRP offers the possibility to create and implement different behaviors of a system which can be used in different assets. The possibility of programming in specially created software applications (Robotino View and Robotino Factory for Robotino 4® and Niryo Studio for Niryo Ned®) for the implementation of the most difficult requirements makes the IMRP a favorable environment for learning and simulation of industrial processes within the laboratory.

The structure includes (main pieces):

- 1x ROBOTINO 4.0
- 1x LASER Range Finder Hokuyo
- 2x Accumulators 18V LI-ION IN PARALLEL
- 1x Inductive sensor SIEA-M12B-UI-S
- 1x Sensor NEBU-M12G5-K-2.5-LE4
- 1x Sensor SOOE-TB-R-PNLK-T
- 1x Sensor NEBU-M8G3-K-2.5-LE3
- 1x ROBOT 6 AXIS NIRYO COBOT
- 1x Power supply 24VDC/12VDC 6A



Practice:

- Object maneuvering
- Movement control
- Obstacle avoidance logic
- Environment mapping
- Principle and function of various industrial sensors
- Transporting objects from one workstation to another

Optional equipment:

- AA600.103.01 - PROSIM V+ ALL IN ONE PC 23.8" i7 (LENOVO)

AA900.060.04 INTELLIGENT 4 WHEELS MOBILE PLATFORM

Description:

The Intelligent 4-Wheels Mobile Platform is a robotic structure which is construction consisting of one mobile robotic platform and a programmable conveyor. The mobile platform is produced by Wheeltec and it adopts mecanum wheels which are compact in structure and flexible in movement. The platform can move forward, backward, laterally and rotate in place.

The structure includes (main pieces):

- 1x Robotic Platform
- 1x M10 LsLiDAR
- 1x ASTRA Depth Camera
- 1x STM32F103RC core board
- 1x Jetson Nano NVIDIA
- 1x Arduino Mega2560 microcontroller
- 1x MD60 100W DC Motor
- 2x VRLA 12V Battery
- 1x CONVEYOR TOOTHED BELT WITH OTT BRUSH DC SERVO DRIVE CAN



Practice:

- Object maneuvering
- Movement control
- Obstacle avoidance logic
- Environment mapping
- Principle and function of various industrial sensors
- Transporting objects from one workstation to another

Optional equipment:

- AA600.103.01 - PROSIM V+ ALL IN ONE PC 23.8" i5 TOUCH

AA900.060.05 ADVANCED MECHATRONICS RESEARCH LAB

Description:

The Advanced Mechatronics Research Lab is a powerful didactic tool used both in academic and industrial courses. Through its enhanced performance and usability, the Advanced Mechatronics Research Lab is one of the best examples of productivity and innovation for device configuration and programming via the SIEMENS Totally Integrated Automation Portal (TIA Portal). The system is composed by two SIEMENS S7-1200 PLCs, two S200 drivers, two servomotors and two linear axes. The Advanced Mechatronics Research Lab is built around two industrial-standard conveyor units each powered by one 1FL6 servomotor. The closed-loop positioning control is assured by the new Siemens servo-drive S200. The motion synchronization is assured by the Siemens S7-1200 PLC via Profinet communication topology. Two robotic arms (Niryo Ned2) are used to move 3D printed objects between multiple local 3D printed storages. Each robot is controlled by one Raspberry PI 4 board used for robot control.

The structure includes (main pieces):

- 1x AA200.002.02 Workstation Mechatronics Research Lab (2000x1000x750)
- 2x AA044.000.04 - PLC S7-1215C TRAINING PANEL Compact (CPU1215C)
- 2x AA047.000.01 - SINAMICS S200 Training Panel (0.4 kW)
- 1x AA600.103.01 - PROSIM V+ALL IN ONE PC27"TOUCH
- 2x Niryo NED2 6-axis Robot
- 2x SIEMENS Servomotor V90/1FL6
- 2x FESTO Linear Axis ELGC-TB-KF-80-500

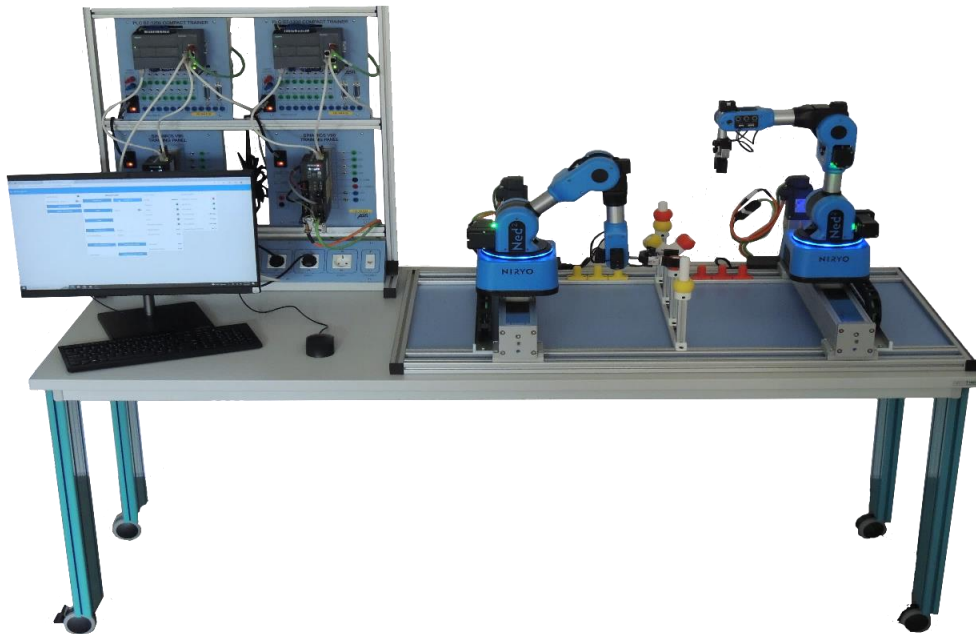

Practice:

- Object maneuvering
- Movement control
- Principle and function of industrial maneuvering robots
- Transporting objects from one storage to another

Optional equipment:

- AA600.103.01 - PROSIM V+ ALL IN ONE PC 23.8" i5 TOUCH
- AA600.102.01 - PROSIM V+ 10.5-inch Tablet Display

AA900.070.01/ AA900.070.02 SMART 3 AXIS CARTESIAN ROBOT STATION

Description:

The SMART 3 Axis Cartesian Robot Station (SACRS) is a didactic system which consists of 3 axis system and an industrial-standard conveyor unit toothed belt controlled by an inverter SinamicsS200. The process synchronization is assured by a SIEMENS S7-1200 PLC and the HMI KTP700. The axis is fitted with a pneumatic gripper to perform a pick and place operation for assembling a final product.

The structure includes (main pieces):

- 1x Workstation MR (800 x 800 x 750) with Modular Supply Panel
- 3x AXIS FESTO (2xELGC, 1xEGSC)
- 3x Servomotors SIEMENS SIMOTICS
- 1x CAMERA IFM ELECTRONIC
- 1x AA047.003.02 SINAMICS S200 3x AXIS DRIVE PANEL (SIEMENS)
- 1x AA094.101.20 CONVEYOR TOOTHED BELT WITH SYNCHRONOUS SERVOMOTOR (S200/1FL2)
- 1x AA096.001.05 CAGE FOR TRAINING ROBOT (safety for CARTESIAN ROBOT)
- 1x AA026.001.03 HMI KTP700 TRAINING CASE with Flexible Support
- 1x AA059.000.09 AIR Compressor SUPERSILENT
- 1x AA059.000.06 Air Supply Filter Regulator

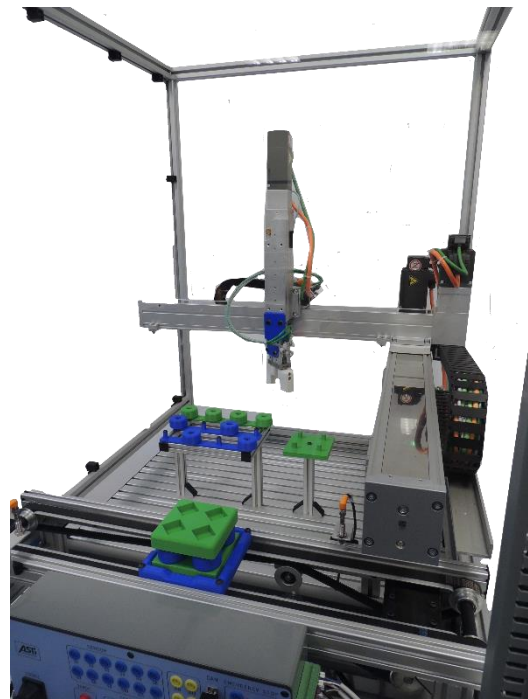

Practice:

- 3D product assembly with 3 axis cartesian system
- Controlling the Servo motors of axis system using SINAMICS S200 Servo Drive
- Controlling the process using SIMATIC S7-1200 & HMI KTP700
- Using 1FL6 servomotors with FESTO axis for high precision positioning

Optional equipment:

- AA600.103.01 - PROSIM V+ ALL IN ONE PC 23.8" i5 TOUCH

AA900.070.03 MECHATRONICS TRAINING SYSTEM (BOSCH REXROTH/ SICK)

Description:

The MECHATRONICS TRAINING SYSTEM is a robust, industrial-grade solution designed for precise and efficient material transport and processing. Built on a durable aluminum frame, it features a conveyor system driven by a Bosch Rexroth servomotor, along with a Bosch Rexroth linear axis for position control. The system is powered by two Bosch Rexroth servo drives, ensuring reliable and accurate motion control.

It includes an SMC guided pneumatic cylinder, an In-Line vacuum ejector and a single-acting gripper for handling tasks. The system's sensory inputs are provided by a photoelectric sensor, a color sensor, a capacitive proximity sensor, and an incremental encoder, allowing for accurate object detection and positioning.

For communication, the system is equipped with two IO-Link masters: a SICK IO-Link Master with 8 ports supporting EtherCAT protocol, and an IFM IO-Link Master with 4 ports, also supporting EtherCAT. These are complemented by an IO-Link IO board and an RFID antenna for advanced tracking and data collection capabilities. Together, these components form a versatile and highly integrated material handling system that offers precise control, real-time communication, and flexible automation options.

The structure includes (main pieces):

- AA019.003.02 - INTDRADRIIVE CS TRAINING PANEL (2 AXIS)
- SICK IO-Link Master with 8 ports and EtherCAT communication
- IFM IO-Link Master with 4 ports and EtherCAT communication
- Aluminum frame
- Conveyor with Bosh Rexroth servomotor
- Bosch Rexroth linear axis with servomotor
- Pneumatic storage unit
- SMC guided pneumatic cylinder
- In-Line vacuum ejector
- Single acting gripper
- Photoelectric sensor
- Color sensor
- Capacitive proximity sensor
- Incremental encoder
- RFID antenna
- IO-Link IO board

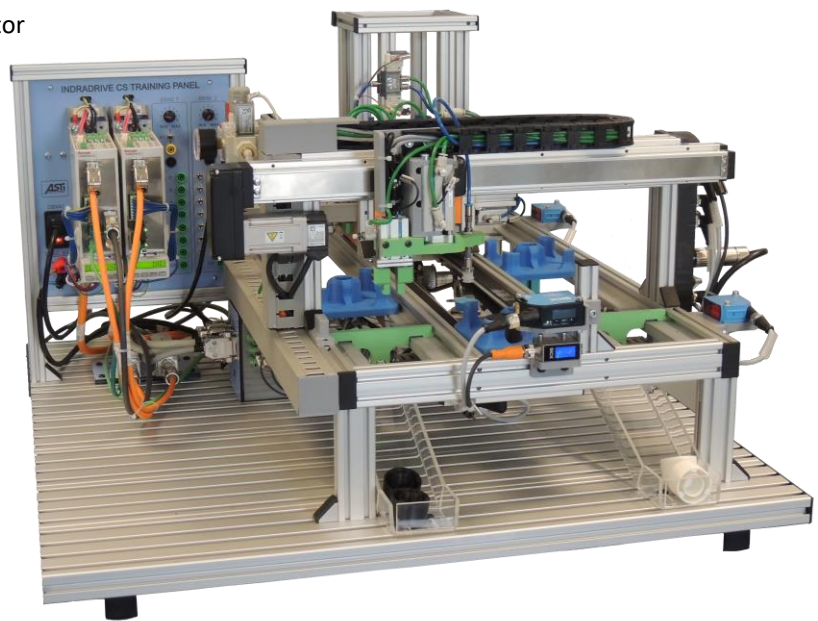

Practice:

- Object sorting by color
- Positioning control using a linear axis
- Vacuum-Based object handling
- RFID-based tracking
- Motion control and synchronization

Recommended equipment:

- AA020.001.01 - PLC CTRLX CORE TRAINING PANEL BOSCH REXROTH

AA900.080.01 INDUSTRIAL COMMUNICATIONS TRAINING SYSTEM (SIEMENS)

Description:

The Communication Training Panel offers a unique configuration, tailored to a different controller type: Siemens. By showcasing the integration complexities, advantages, and drawbacks of various industrial communication protocols, the training system integrates the most widely used protocols in the industry. By simulating real-world scenarios, it provides invaluable insights into the intricacies of communication systems, enabling learners to gain practical experience and deepen their understanding of industrial networking technologies.

The structure includes (main pieces):

- AA073.001.04 PLC COMMUNICATIONS TRAINING PANEL (S7-1200)
- AA060.000.10 Profinet coupler (DIO, IO-LINK) IFM
- AA060.000.11 Profibus coupler (DIO, IO-LINK) IFM
- AA060.000.12 Modbus TCP coupler (DIO, IO-LINK) IFM
- AA060.101.01 Temperature Sensor with Display (IO-LINK) IFM
- AA060.101.03 RFID Sensor Coupler (IO-LINK) IFM
- AA200.000.15 TABLETOP STAND for Training Panels (Modbus RTU PAC 1600)
- AA600.103.02 DataManagement (" PC 23.8" i7) (with TIA PORTAL)



Practice:

- Industrial communication protocol setup
- Comparison between various types of protocols used by Siemens (Profinet, Profibus, Modbus, IoLink)
- Basic Siemens PLC programming

Optional equipment:

- AA071.000.05 - HMI MTP700 COMFORT TRAINING PANEL

AA900.080.02 INDUSTRIAL COMMUNICATIONS TRAINING SYSTEM (BECKHOFF)

Description:

The Communication Training Panel presents a specialized configuration tailored specifically for Siemens controllers, providing a comprehensive platform for learners. This training system is designed to demonstrate the integration challenges, benefits, and limitations of a wide range of industrial communication protocols. By incorporating and showcasing some of the most used protocols in the industry, the system allows participants to explore and analyze real-world communication scenarios in a controlled environment. Through these simulations, users can gain deep insights into the complexities of industrial communication systems, including the nuances of protocol interaction, troubleshooting, and optimization. By offering practical, hands-on experience, the panel enables learners to develop a solid understanding of industrial networking technologies, equipping them with the skills needed to navigate the intricacies of modern communication infrastructures in industrial settings.

The structure includes (main pieces):

- AA022.201.01 BECKHOFF COMM Training Panel (Coupler)
- AA060.000.13 EtherCat COUPLER (DIO, IO-LINK) IFM
- AA060.000.14 EthernetIP COUPLER (DIO, IO-LINK) IFM
- AA022.301.01 DeviceNet coupler (DIO) Beckhoff
- AA022.301.02 CANOpen coupler (DIO) Beckhoff
- AA060.101.02 RFID Sensor Coupler (CANOpen) IFM
- AA200.000.15 TABLETOP STAND for Training Panels (1AC+PAC 1600)
- AA600.103.02 DataManagement (" PC 23.8" i7)

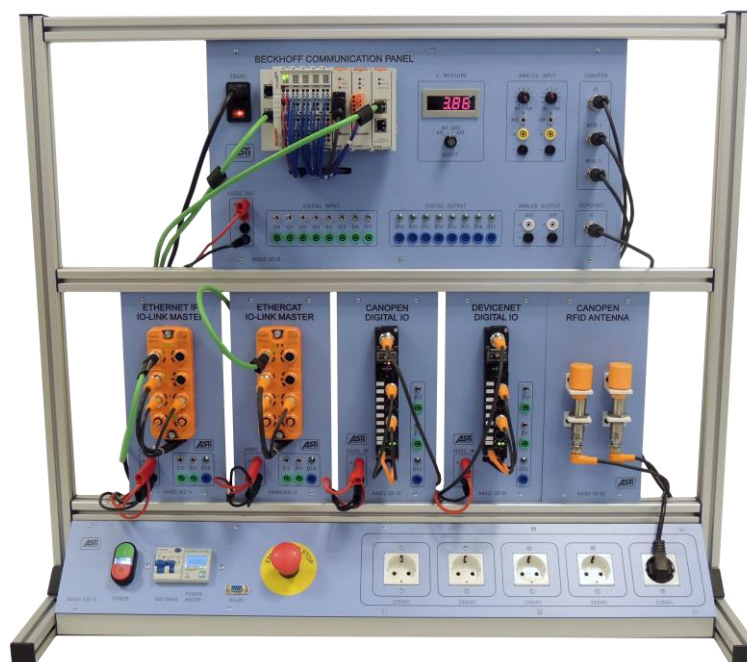

Practice:

- Industrial communication protocol setup
- Comparison between various types of protocols used by Beckhoff (EtherCat, EtherNet/IP, CanOpen, DeviceNet)
- Basic Beckhoff PLC programming

Optional equipment:

- AA071.000.05 - HMI MTP700 COMFORT TRAINING PANEL

TRAINING COURSES - SKILLS TRAINING FOR INDUSTRY

The courses are presented in a helpful and informative way, making frequent reference to typical electrical design problems, and offering practical solutions. The courses employ large numbers of practical activities where candidates are given the opportunity to 'learn by doing'. The use of real industrial components in practical exercises ensures that the experiences are realistic and relevant.

AA-STC100: SENSORS AND TRANSDUCERS IN CONTROL ENGINEERING

Identify and understand the purpose of typical sensors and transducer types: inductive, capacitive, optic. Sensor topology: IO-Link, AS-I, RFID and develop an automation solution.

AA-CLC200: CLOSED-LOOP CONTROL IN PROCESS ENGINEERING

Components of closed loop / open loop control system, cascade control loop functionality and cascade control advantages for a single element. Principles, characteristics of a P, PI, PD and PID control and control loop monitoring.

AA-SIM300: SIMATIC S7 PRACTICAL COURSE - BASIC LEVEL

Set up and commission a SIMATIC S7-300 / S7-1200 / S7-1500 PLC, create and change a hardware configuration. Know the basic instruction set. Create a program with different modules. Identify and eliminate errors using diagnostic tools.

AA-SIM310: SIMATIC S7 PRACTICAL COURSE - ADVANCED LEVEL

Implement applications with analog values, use analog output, connect analog input / output components correctly. Use algorithms (PID bidirectional) for control level, flow. Adjust the parameters of the PID algorithm. Test the control systems.

AA-TWI400: BECKHOFF TwinCat 2 PRACTICAL & PROGRAMMING COURSE

Structure and functions of BECKHOFF PLCs, automation structures buses (E-Bus, K-Bus), EtherCAT communication protocol, functions of TwinCAT 2 programming, faults simulations and maintenance work with Beckhoff equipment.

AA-TWI410: Beckhoff TwinCAT 3 PRACTICAL & PROGRAMMING COURSE

Structure and functions of BECKHOFF PLCs, automation structures and communication buses (E-Bus, K-Bus), EtherCAT communication protocol, functions of TwinCAT 3 programming environment, graphical interfaces, and faults simulations.

AA-INC500: INDUSTRIAL NETWORK COMMUNICATION COURSE

Communication architectures; practical applications for design, configuration, and use of systems with communication skills PROFINET, PROFIBUS, Modbus TCP/RTU, AS-Interface, IO-Link; commissioning, testing and error detection.

AA-SCA600: INDUSTRIAL PROCESS MONITORING - SCADA software

Implement applications for acquisition and conditioning of process variables, control loops for level, debit, and pressure; Implement screens with control elements, graphs, alerting and alarms, commissioning and testing of the SCADA system.

AA-IDC700: AC INVERTER DRIVES COURSE - BASIC LEVEL

Design scheme for frequency converter installations; Understand the structure, principles of operation and installation of a frequency converter; Parameterize, program a frequency converter; Processes that require the use of frequency converters.

AA-LMC710: Linear Motion Control Course

Understand, describe, and analyze a closed loop control for motion control; Parametrize and configure a servo drive with FCT. Develop and commission a motion control application with PLC; Operate motion control driver (backup, restore, diagnostic).

AA-AMC720: ADVANCED MOTION CONTROL COURSE

Parametrize and configure a servo drive with TIA Portal; Implement a camming application; Implement a gearing application; Use TIA Portal as a maintenance tool for the camming/gearing applications.

AA-ROB800: MODULAR ROBOT CELL - PROGRAMMING & COMMISSIONING - basic level

Establish communication between the robot and its external controller; Communication between the robot controller and a SIEMENS PLC / Sinamics driver; Understanding pick and place applications using ABB robot and Siemens PLC.

AA-ROB810: MODULAR ROBOT CELL - programming & commissioning - advanced level

Implementing pick and place applications using ABB robot and Siemens PLC; Implementing assembly applications using ABB robot and Siemens PLC; Implementing transability applications using ABB robot, Siemens PLC, and RFID system.

AA-IDM900: INDUSTRIAL DATA MINING

Focus on a systematic approach and techniques for managing large data sets, building, and improving predictive models for solving practical issues. This leads to defining and answering key engineering and management questions by having control over the tuning aspects and design decisions behind high level machine learning tools and frameworks.

AA-STC100: SENSORS AND TRANSDUCERS IN CONTROL ENGINEERING



Content:

- Sensors and transducers – introduction
- Inductive sensors
- Capacitive sensors
- Optic sensors
- Data acquisition
- Communication protocols - introduction
- IO-Link – general characteristics and configuration
- AS-I – general characteristics and configuration
- Profinet – general characteristics and configuration
- RFID – general characteristics and configuration
- Practical exercises with conveyor system
- Operate and maintenance procedures

Target group*: Electricians and engineers

Description:

The quality of an automation solution is strongly influenced by the quality of the measurement of the process parameters. This course provides basic knowledge about structured and effective principles and notions regarding sensors and transducers as well as their use in industrial processes. Parametrization, measurement, and monitoring applications will be carried out through structures involving sensors and transducers. As a necessity in the current automation environment, the field communication layer will be included in relation to the industrial sensors. Protocols such as IO-Link and AS-I and Profinet will be used in the practical exercises.

Objectives:

At the end of this seminar, the trainees will be able to:

- Identify and understand the purpose of typical sensors and transducer types: inductive, capacitive, optic
- Configure an IO-Link sensor topology
- Configure an AS-i sensor topology
- Operate systems with different types of sensors and communication topologies
- Develop an automation solution

Duration: 3 days

AA-CLC200: CLOSED-LOOP CONTROL IN PROCESS ENGINEERING



Content:

- Components of closed loop / open loop control system, including static and dynamic features
- Requirements for Open and Closed Loop Control, Stability, Adjustment and Control Methods
- Cascade control loop functionality and cascade control advantages for a single element
- Principles, characteristics of a P, PI, PD and PID control
- Control loop monitoring
- Security and operation of control loop systems

Target group*: Electricians and engineers

Description:

Controlling a process involves ensuring all the means and methods necessary for its evolution, closed loop, and open loop control being essential to provide the requirements of economic efficiency, quality, and safe operation. This course provides knowledge related to structured and efficient automation engineering concepts.

Objectives:

At the end of this seminar, the trainees will be able to:

- Command a closed loop / open loop control system
- Initiate and modify closed loop / open loop control systems
- Identify the components of a closed loop / open loop control
- Read a circuit diagram
- Connect components according to a circuit diagram
- Operate, describe, identify, and analyze a closed loop /open loop control system
- Know the basics of closed loop / open loop control

Duration: 3 days

(*): Enrollment and participation in this course require basic knowledge in the field

AA-SIM300: SIMATIC S7 PRACTICAL COURSE - BASIC LEVEL



Content:

- The basic structure of a SIMATIC S7-300 / S7-1200
- Presentation of programming languages LAD, FBD and SCL in TIA Portal
- Global variable categories, data types and addressing modes
- Elementary logic instruction set
- Numerical instructions: timing, counting
- Arithmetic instructions
- Designing and implementing solutions to solve practical applications: electric motors control, pumping system, traffic lights and conveyor belts

Target group*: Electricians and engineers

Description:

In this course, you will learn the structure and operation of a SIMATIC S7 PLC. A key element of the course is the use of an industrial process simulator to exemplify and solve some exercises that highlight the main functions commonly used in PLC (logic functions, counters, timers, comparators, etc.). The proposed scenarios are based on applications such as electric motors control, pumping system, traffic lights and conveyor belts.

Objectives:

At the end of this seminar, the trainees will be able to:

- Set up and commission a SIMATIC S7-300 / S7-1200 PLC
- Understand, create, and change a hardware configuration
- Know the basic instruction set
- Create and use a program for the SIMATIC S7-300 /S7-1200 PLC
- Combine different program modules
- Identify and eliminate errors using diagnostic tools

Duration: 4 days

AA-SIM310: SIMATIC S7 PRACTICAL COURSE - ADVANCED LEVEL



Content:

- Processing of analog values
- Analog-numeric or numeric-analog conversion
- Standardization of analog input signals
- Upper and lower limits of analog values
- Differences between local variables and global variables
- 16/32-bit conversions
- Voltage/Current Input / Output Signals
- Analog sensors/analog actuators
- Open-loop control and closed-loop control, bi-positional control
- PID control algorithm with flow and level control applications

Target group*: Electricians and engineers

Description:

In this course, you will learn to use the Simatic S7 PLCs instruction set to process analog values and the PID control algorithm so you can achieve a closed-loop control system. A key element of the course is the use of equipment (ASTANK 2) introducing process engineering and closed-loop control. In this course, special attention is placed on the topics of complex hardware and software diagnostic functions, on the integrated PID controller technology functions and drive functions. There will be applications for measuring and controlling process parameters (flow, level, pressure) in open or closed loop, using classical control algorithms.

Objectives:

At the end of this seminar, the trainees will be able to:

- Implement applications that involve the processing of analog values
- Integrate analog elements into a PLC program
- Use analog output values, connect analog input / output components correctly
- Implement bidirectional or PID bidirectional (level, flow, flow) control structures
- Adjust the parameters of the PID algorithm
- Run and test the control systems

Duration: 4 days

(*): Enrollment and participation in this course require basic knowledge in the field

AA-TWI400: BECKHOFF TWINCAT 2 PRACTICAL & PROGRAMMING COURSE



Content:

- Structure and functions of a programmable logic controllers
- Overview of IEC 61131-3 standard and programming languages: IL, ST, LAD, FBD, SFC, CFC
- Automation structures and communication buses (E-Bus, K-Bus)
- EtherCAT communication protocol
- Functions of TwinCAT 2 programming environment
- Graphical interfaces
- Faults simulations and maintenance work with Beckhoff equipment
- The last day can be reserved for the presentation of the TwinCAT 3 programming environment

Target group*: Electricians and engineers

Description:

In terms of professional training, both in the design of new automation solutions as well as in the process of maintenance and improvement, it is necessary to master certain notions about programmable logic controllers. In the case of Beckhoff, the automation elements present certain properties that once known, lead to efficient exploitation of the automation components. The trainee will be familiar with the programming languages specified in IEC61131-3 as well as the parameterization, monitoring and programming software.

Objectives:

At the end of this seminar, the trainees will be able to:

- Identify Beckhoff equipment
- Use and combine different programming languages for automation solutions
- To program IEC 61131-3 compatible equipment
- Use different types of variables (local/global)
- Use simulation, test and troubleshooting tools
- Provide visualization interfaces for maintenance
- Identify and isolate communication problems
- Identify the operating state of coupled elements in an EtherCAT topology

Duration: 4 days

AA-TWI410: BECKHOFF TWINCAT 3 PRACTICAL & PROGRAMMING COURSE



Content:

- Structure and functions of PLCs
- Overview of IEC 61131-3 standard and programming languages: IL, ST, LAD, FBD, SFC, CFC
- Automation structures and communication buses (E-Bus, K-Bus)
- TwinCAT 2 – TwinCAT 3 comparison: advantages and new functionalities
- EtherCAT communication protocol
- Functions of TwinCAT 3 programming environment
- Faults simulations and maintenance work with Beckhoff equipment

Target group*: Electricians and engineers

Description:

Considering the current situation in industrial automation we can distinguish a tendency to improve the flexibility and adaptability of technological processes. In this context, TwinCAT 3 comes as a natural development of the real-time control software TwinCAT 2. The "only one software for programming and configuration" brings many advantages and new features to PC-based control technology. This course can be considered a starting point in career development in industrial automation.

Objectives:

At the end of this seminar, the trainees will be able to:

- Identify Beckhoff equipment
- Use and combine different programming languages for automation solutions
- To program IEC 61131-3 compatible equipment
- Use simulation, test and troubleshooting tools
- Provide visualization interfaces for maintenance
- Identify the operating state of coupled elements in an EtherCAT topology
- Use different types of variables (local/global)

Duration: 4 days

(*): Enrollment and participation in this course require basic knowledge in the field

AA-INC500: INDUSTRIAL NETWORK COMMUNICATION COURSE



Content:

- Serial and parallel communications
- Network topologies
- Presentation of industrial communication networks
- Features of various industrial communications systems
- Differences between centralized and decentralized driving systems Communication architectures
- Practical applications for design, configuration, and implementation of systems with communication skills PROFINET, PROFIBUS, Modbus TCP/RTU, AS-Interface and IO-Link
- Commissioning, system testing and error detection

Target group*: Electricians and engineers

Description:

Currently, industrial communication networks are an indispensable component of automation systems. This course aims at presenting the usual communication networks, both through the presentation of theoretical knowledge and especially through practical examples. There are various practical exercises that most often involve the interconnection of devices with multiple communication abilities so that the main features and particularities of the usual industrial communication networks are highlighted.

Objectives:

At the end of this seminar, the trainees will be able to:

- Design an industrial communication network
- Choose appropriate industrial communication network
- Make a distinction between common industrial communication systems
- Use different communication systems in practical applications
 - Identify and eliminate errors using diagnostic tools

Duration: 4 days

AA-SCA600: INDUSTRIAL PROCESS MONITORING - SCADA SOFTWARE

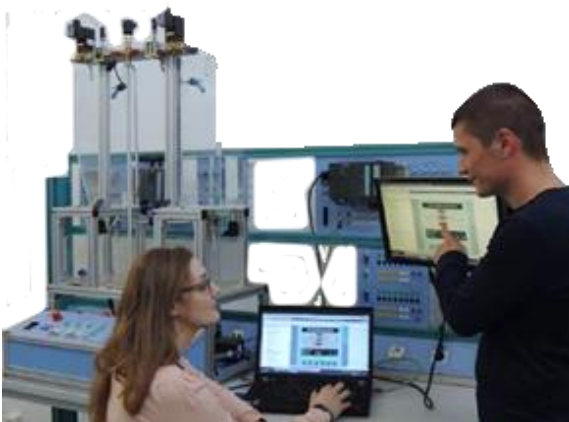

Content:

- Acquisition and conditioning of process variables
- Implementing supervisory screens (TIA Portal WinCC)
- The set of available instruments for visualization and control
- Define alarms, usage of evolution graphs
- Study of static and dynamic characteristics of transducers and actuators
- Analytic modeling and experimental identification of industrial processes (level, flow)
- Open and closed loop control
 - Classic PID control algorithms, cascade control loops

Target group*: Electricians and engineers

Description:

In this course, you will learn to achieve a control system using SIMATIC S7 PLCs and visual interfaces to provide automatic control of process parameters and a detailed view of the plant. This course gives you the general basics of SCADA operating and monitoring based on Simatic WinCC. Also, the trainees will learn about creating projects, configuring display images, parameterizing messages, graphic alarm display and alarm logging, curve display, tag logging, all by doing practical exercises in hands-on modules.

Objectives:

At the end of this seminar, the trainees will be able to:

- Implement applications for acquisition and conditioning of process variables
- Implement control loops for level, debit, and pressure
- Adjust the parameters of control algorithms through various methods
- Implement SCADA screens with control elements, graphs, alerting and alarms
- Commissioning and testing of the SCADA system

Duration: 4 days

(*): Enrollment and participation in this course require basic knowledge in the field

AA-IDC700: AC INVERTER DRIVE COURSE - BASIC LEVEL



Content:

- Symbols and electrical schemes for frequency inverter installations
- Basic structure of a frequency converter (power electronics, control electronics)
- The design, operation, and installation of a frequency converter
- User interface – parametrization and configuration
- Programming the hardware and software functions of the frequency converters
- Industrial communication protocols (PROFINET)
- Techniques for optimizing industrial processes by using frequency
- Design and implementation of practical applications: motor control, starting of star-delta, acceleration, and deceleration control

Target group*: Electricians, engineers, and system operators

Description:

The need for speed control according to various parameters in the industrial process via frequency converters is essential in modern automation applications. This course will provide the knowledge to learn structured and efficient principles and notions about the applicability, utility, choice, and configuration of frequency converters according to the technological process characteristics. Parametrization, measurement, and monitoring applications will be carried out through structures involving frequency converters.

Objectives:

At the end of this seminar, the trainees will be able to:

- Design an electrical scheme for frequency converter installations
- Interpret the characteristics of a frequency converter in accordance with the requirements of an application
- Use the frequency converter interface
- Parameterize and program a frequency converter
- For an overview of the industrial processes that require the use of frequency converters
- Understand the structure, principles of operation and installation of a frequency converter

Duration: 3 days

AA-LMC710: LINEAR MOTION CONTROL COURSE



Content:

- Motion control elements – short theoretical presentation (servo, stepper, encoder, motion profile, drive)
- Drives configuration and parametrization considering different motor types and mechanical solutions in Festo Configuration Tool (FCT)
- Motion profiles
- Step7/TIA Portal programming
- Profinet/ Profibus for PLC – motion drive connection
- LD programming language
- Elementary logic instruction set; Operation and maintenance

Target group*: Electricians, mechanics, and engineers

Description:

This training course includes basic concepts and practical application for linear motion control. The trainee will learn about stepper and servo motors, encoders, linear actuators, drives and Profinet or Profibus communication. Moreover, the practical applications will include PLC programming in TIA Portal or Step7 for drive control. The theoretical part will include notions about close loop control for speed and position.

Objectives:

At the end of this seminar, the trainees will be able to:

- Understand, describe, and analyze a closed loop control for motion control
- Parameterize and configure a servo drive with FCT
- Configure Profinet communication between a motion drive and a PLC
- Develop and commission a motion control application with PLC
- Operate and maintain a motion control driver (backup, restore, diagnostic)

Duration: 3 days

(*): Enrollment and participation in this course require basic knowledge in the field

AA-AMC720: ADVANCED MOTION CONTROL COURSE

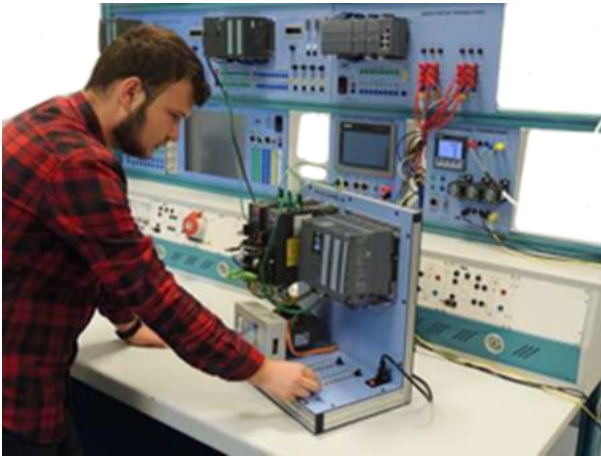

Description:

To ensure the flexibility and versatility of the production lines, the motion control solutions present an increasing interest in the current industrial environment. Functionalities such as speed control, positioning, cam disc, cam/cam track, gearing can be easily integrated using servo drive such as S200 and technology control process unit. The course proposes multiple motion control scenarios using real industrial equipment. The trainee will focus on parametrization and programming to control 2 servomotors.

The exercises will provide the hardware background for operation and maintenance work.

Content:

- Identify the needed hardware for motion control solutions
- Overview of technology logic controller capabilities
- First steps in TIA Portal for parametrization and programming
- Overview of Profinet
- LD and SCL programming language
- Elementary logic instruction set
- Camming
- Gearing
- Operation and maintenance

Objectives:

At the end of this seminar, the trainees will be able to:

- Understand, describe, and analyze a closed loop control
- Parametrize and configure a servo drive with TIA Portal
- Configure Profinet communication between a servo-drive and a technology controller
- Implement a camming application
- Implement a gearing application
- Use TIA Portal as a maintenance tool for the camming/gearing applications

Target group*: Electricians, mechanics, and engineers

Duration: 3 days

(*): Enrollment and participation in this course require basic knowledge in the field

AA-ROB810: MODULAR ROBOT CELL – PROGRAMMING & COMMISSIONING - ADVANCED LEVEL



Description:

As a result of the exponential evolution of robotics over the last decade, this technology has become essential in modern manufacturing processes, offering added safety, repeatability, precision, and quality. This course provides an overview of robot-based technological processes through a systematic approach of the basic concepts of industrial robot programming within manufacturing structures. The current concepts related to robot programming will be outlined and exemplified with real industry applications. This theoretical introduction will be followed by practical applications for the configuration: ABB IRB 120 programming using the operator panel, Siemens Simatic S7 programming via TIA Portal framework, RFID configuration, Profinet communication, vision camera, Sinamics drive configuration and multiple industrial sensors and transducers.

Content:

- Introduction in integrated robot cells: automation structures, sensors, communication buses, drives, PLCs, RFID and HMI
- Overview of RAPID programming for ABB robots, Siemens TIA Portal programming for PLCs and HMIs
- Teaching, saving, and adjusting robot targets
- Implement and modify robot movements between working positions
- Parametrization and commissioning for industrial conveyor with Sinamics drive
- Vision camera (3D sensors)
- Deployment of Profinet industrial network
- Pick and place exercises with industrial robots
- Product assembly exercises using industrial robots and multiple automation equipment
- RFID exercises for product traceability

Objectives:

At the end of this seminar, the trainees will be able to:

- Use and combine different hardware and software applications to deliver professional and quick solutions
- Establish communication between the robot and its external controller
- Effectuate the communication between the robot controller and a SIEMENS PLC, respectively a SIEMENS Sinamics driver
- Implementing pick and place applications using ABB robot and Siemens PLC
- Implementing assembly applications using ABB robot and Siemens PLC
- Implementing traceability applications using ABB robot, Siemens PLC and RFID system
- Gain some insight into industrial processes that use robots

Target group*: Electricians and engineers with application experience

Duration: 4 days

(*): Enrollment and participation in this course require some basic knowledge in the field of industrial automation

PORTOFOLIO

SHOWROOM FOR TECHNICAL TRAINING SOLUTIONS



INTERNATIONAL CONFERENCES



EBA

Egyptian Businessmen's Association

جمعية رجال الأعمال المصريين



TECHNICAL TRAINING EXHIBITIONS

Welcome to HANNOVER MESSE 2017

POLAND









MANUFACTURING FACILITY



CODE NUMBER	PRODUCT NAME	PAGE
AA001.001.01	DATA ACQUISITION TRAINING PANEL (NI USB 6001)	29
AA001.002.01	DATA ACQUISITION TRAINING PANEL (NI USB 6002)	29
AA007.000.09	CMMP-AS MOTION CONTROL TRAINING PANEL (SERVO)	28
AA007.000.10	CMMS-ST MOTION CONTROL TRAINING PANEL (STEPPER)	28
AA008.000.01	SERVO DRIVE FESTO TRAINING CASE (MINI-SLIDE ACTUATOR)	28
AA008.000.02	SERVO DRIVE FESTO TRAINING CASE (TOOTHED BELT AXIS)	28
AA008.000.03	PLC FESTO & HMI TRAINING CASE	28
AA008.000.04	3-AXIS FESTO CARTESIAN ROBOT DEMO CASE	28
AA010.000.02	MOTOR CONTROL TRAINING PANEL 3-PHASE SUPPLY	23
AA011.000.02	MOTOR CONTROL TRAINING PANEL CONTROL UNIT	23
AA017.100.09	AC MOTOR & ENCODER (3xAC MOTOR, 0.37 kW)	23
AA017.300.01	SOFT STARTER TRAINING PANEL (1.5 kW, 400 V)	25
AA017.400.01	SOFT STARTER TRAINING CASE	25
AA018.100.01	3AC ASYNC. MOTOR 1.5kW 4 pole 180 RPM	23
AA019.003.02	INDRADRIVE CS TRAINING PANEL (2 AXIS) BOSCH	25
AA020.001.01	PLC ctrlX CORE TRAINING PANEL	10
AA021.001.01	CTRLX HMI INTERFACE CASE	14
AA022.000.02	COUPLER TRAINING PANEL (EK9000 ASTANK-2+)	30
AA022.100.03	BECKHOFF PLC & HMI TRAINING PANEL (CX9020 & CP6606)	10
AA022.101.01	BECKHOFF PLC CX TRAINING PANEL (CX9020)	10
AA022.101.02	BECKHOFF COUPLER TRAINING PANEL (EK1100)	10
AA022.101.03	BECKHOFF COUPLER TRAINING PANEL (EK9000)	10
AA022.201.01	BECKHOFF COMMUNICATIONS TRAINING PANEL (COUPLER)	17
AA022.301.01	DEVICENET DIGITAL IO PANEL	17
AA022.301.02	CANOPEN DIGITAL IO PANEL	17
AA023.000.02	IO-LINK COMMUNICATION TRAINING PANEL	16
AA023.001.01	ALLEN BRADLEY PLC TRAINING PANEL (COMPACT LOGIX)	11
AA023.002.01	ALLEN BRADLEY PLC TRAINING PANEL (COMPACT LOGIX 1769)	11
AA024.000.01	ALLEN BRADLEY PLC TRAINING PANEL (CONTROL LOGIX 1756-L71)	11
AA025.000.03	LOGO! 0BA8 TRAINING PANEL COMPACT	9
AA025.000.05	NANOLINE TRAINING PANEL COMPACT	11
AA025.000.10	ZELIO TRAINING PANEL	12
AA025.001.04	LOGO! 0BA8 TRAINING PANEL (DM8, AM2, AQ)	9
AA025.001.07	NANOLINE TRAINING PANEL	11
AA025.001.11	ZELIO TRAINING PANEL	12
AA025.002.03	LOGO! 0BA8 DIDACTIC PANEL COMPACT	9
AA026.000.03	HMI KTP700 TRAINING PANEL	14
AA026.001.03	HMI KTP700 TRAINING CASE WITH FLEXIBLE SUPPORT	14
AA026.002.03	HMI KTP700 CASE (CPS) WITH FLEXIBLE SUPPORT	14
AA026.002.04	KTP700 HMI INTERFACE CASE	14
AA027.000.01	HMI CP6606 TRAINING PANEL	14
AA028.001.02	TRAFFIC SIGNAL PANEL	33
AA029.000.01	HMI PANELVIEW 800 TRAINING PANEL	14
AA029.000.02	HMI PANELVIEW PLUS 7 TRAINING PANEL	14
AA030.000.01	HMI HMIST6400 TRAINING PANEL	14
AA031.010.04	VALS SIEMENS CONDITION MONITORING (S7-1281)	29
AA031.010.05	VALS IFM CONDITION MONITORING (VSE 150)	29
AA041.001.01	ENERGY METER EEM MA250 TRAINING PANEL	21
AA042.000.02	SINAMICS G120 PN TRAINING PANEL (1xAC, 230V, 0.37 kW)	22
AA042.000.03	SINAMICS G120 PN TRAINING PANEL (1xAC, 230V, 0.37 kW)	22
AA042.000.04	SINAMICS G120 PN TRAINING PANEL (1xAC, 230V, 1.5 kW)	22
AA042.001.01	SINAMICS G120X TRAINING PANEL (3xAC, 400V, 0.75 kW)	22
AA042.001.02	SINAMICS G120PN TRAINING PANEL (3xAC, 400V, 0.55 kW)	22
AA042.001.03	SINAMICS G120PN TRAINING PANEL (3xAC, 400V, 0.55 kW)	22
AA042.001.04	SINAMICS G120 PN TRAINING PANEL (3xAC, 400V, 1.5 kW)	22
AA042.001.05	SINAMICS G120C PN TRAINING PANEL (3xAC, 400V, 0.75kW)	22
AA042.002.02	SINAMICS V20 MODBUS TRAINING PANEL (3xAC, 400 V, 0.55 kW)	22
AA042.003.02	SINAMICS V20 MODBUS TRAINING PANEL (1xAC, 230V, 0.37 kW)	23
AA042.011.04	SINAMICS G120PN TRAINING PANEL (3xAC, 400V, 1.5kW, Encoder)	22
AA044.000.03	PLC S7-1215C TRAINING PANEL COMPACT (CPU1215C)	8
AA044.000.04	PLC S7-1215C TRAINING PANEL COMPACT (CPU1215C)	8
AA044.000.06	PLC S7-1214C TRAINING PANEL COMPACT (CPU 1214C)	8
AA044.000.07	PLC S7-1215C TRAINING PANEL COMPACT (CPU1215C)	8
AA044.001.01	PLC S7-1215C TRAINING PANEL (CPU1215C)	8
AA044.001.02	PLC S7-1215C TRAINING PANEL (CPU1215C)	8
AA044.001.03	PLC S7-1215C TRAINING PANEL (CPU1215C)	8

AA044.001.04	PLC TRAINING PANEL & MOTOR CONTROL	25
AA044.001.05	PLC S7-1214C TRAINING PANEL (CPU 1214C)	8
AA044.002.02	PLC S7-1212C TRAINING PANEL (CPU1212C)	8
AA044.002.03	PLC S7-1212C TRAINING PANEL COMPACT (CPU1212C)	8
AA044.002.04	PLC S7-1212C TRAINING PANEL COMPACT (CPU1212C)	8
AA044.200.01	TIM 4R-IE TRAINING PANEL	29
AA045.000.01	SINAMICS V90 TRAINING PANEL (1xAC, 230V, 0.4 kW)	24
AA045.001.01	TRAINING SYSTEM FOR SERVOMOTOR (1AC V90, SERVO 1FL6 0.4kW)	24
AA045.002.01	TRAINING SYSTEM FOR MOTION CONTROL (2x 1AC V90, 2x SERVO 1FL6 0.4 kW)	24
AA045.003.02	SINAMICS V90 2xAXIS DRIVE PANEL (2x 1AC V90 0.4 kW)	24
AA045.003.03	SINAMICS V90 3xAXIS DRIVE PANEL (3x 1AC V90, 0.4kW)	24
AA046.000.01	SINAMICS S210 TRAINING PANEL (1AC, 230V, 0.4 kW)	24
AA046.001.01	TRAINING SYSTEM FOR SERVOMOTOR (1 Ph S210, SERVO 1FK2 0.4 kW)	24
AA046.002.01	MOTION CONTROL SINAMICS S210 TRAINING SYSTEM (1FK2, 0.4kW)	24
AA046.003.02	SINAMICS S210 2xAXIS DRIVE PANEL (2x1AC S210, 0.4kW)	24
AA046.003.03	SINAMICS S210 3xAXIS DRIVE PANEL (3x1AC S210, 0.4kW)	24
AA047.000.01	SINAMICS S200 TRAINING PANEL (1AC, 230V, 0.4kW)	25
AA047.001.01	TRAINING SYSTEM FOR SERVOMOTOR (1AC S200, SERVO 1FL2, 0.4kW)	25
AA047.002.01	MOTION CONTROL SINAMICS S200 TRAINING SYSTEM (1FL2, 0.4kW)	25
AA047.003.02	SINAMICS S200 2xAXIS DRIVE PANEL (2x1AC S200, 0.4kW)	25
AA047.003.03	SINAMICS S200 3xAXIS DRIVE PANEL (3x1AC S200, 0.4kW)	25
AA048.001.03	PLC S7-1516 TRAINING PANEL (CPU 1516-3PN/DP)	7
AA048.001.04	PLC S7-1516F TRAINING PANEL (CPU 1516F-3PN/DP)	18
AA048.001.05	PLC S7-1512C TRAINING PANEL (CPU 1512C-1PN)	7
AA048.001.07	PLC S7-1513 TRAINING PANEL (CPU 1513-1PN)	7
AA048.010.07	PLC S7-1513 TRAINING PANEL (CPU1513-1PN)	7
AA049.001.01	PLC S7-1511T TRAINING PANEL (CPU1511T-1PN)	25
AA050.000.01	REMOTE COMMUNICATION PANEL (SITEMANAGER)	17
AA050.100.01	REMOTE COMMUNICATION LICENCE (LINKMANAGER)	17
AA051.000.01	PLC M221 TRAINING PANEL (CPUTM221ME32TK)	12
AA051.001.01	PLC M221 TRAINING PANEL (CPUTM221ME32TK)	11
AA051.002.01	PLC M221 TRAINING PANEL (CPUTM221ME32TK)	11
AA052.001.01	PLC X20 TRAINING PANEL (X20CP0482)	12
AA052.001.02	PLC X20 TRAINING PANEL (X20CP1586)	12
AA052.002.01	PLC X20 TRAINING PANEL (X20CP0482+T30)	12
AA052.002.02	PLC X20 TRAINING PANEL (X20CP1586+T30)	12
AA052.003.01	PLC X20 TRAINING PANEL (X20CP0482+T50)	12
AA052.003.02	PLC X20 TRAINING PANEL (X20CP1586+T50)	12
AA054.000.01	IWLAN ACCESS POINT	16
AA054.001.01	IE SCALANCE XC208 SWITCH PANEL	16
AA054.200.02	SIMATIC IOT2050 TRAINING PANEL	15
AA054.300.01	MINDCONNECT NANO PANEL	15
AA054.300.02	SIMATIC INDUSTRIAL EDGE PANEL	15
AA054.400.01	NETWORK SECURITY TRAINING PANEL	15
AA055.000.01	POWER SUPPLY 24VDC, 3A	21
AA055.100.01	POWER BATTERY 12/24V 1.3AH	21
AA056.001.01	HART TEMPERATURE TRANSMITTER BOARD (SITRANS TH300)	29
AA056.002.01	PROFIBUS PA TEMPERATURE TRANSMITTER BOARD (SITRANS TH400)	29
AA056.100.01	HART USB CONFIGURATOR	29
AA059.000.04	SMART RELAY E-PNEUMATIC (NANOLINE)	27
AA059.000.05	SMART RELAY E-PNEUMATIC (LOGO! OBA8)	27
AA059.000.06	AIR SUPPLY FILTER REGULATOR	28
AA059.000.08	E-PNEUMATIC SMC TRAINING SYSTEM	27
AA059.000.09	AIR COMPRESSOR SUPERSILENT	33
AA059.000.10	E-PNEUMATIC FESTO TRAINING SYSTEM	27
AA059.001.08	SMART ENERGY E-PNEUMATIC PANEL (SMC)	28
AA060.000.02	AS-I AC402S TRAINING PANEL	19
AA060.000.03	IO-LINK MASTER(PN/ETHERCAT) TRAINING PANEL	16
AA060.000.05	IO-LINK MASTER (PROFINET) & DIGITAL I/O PANEL	16
AA060.000.10	PROFINET IO-LINK MASTER PANEL (DIO, IO-LINK) IFM	16
AA060.000.11	PROFIBUS IO-LINK MASTER PANEL (DIO, IO-LINK) IFM	17
AA060.000.12	MODBUS TCP IO-LINK MASTER PANEL (DIO, IO-LINK) IFM	17
AA060.000.13	ETHERCAT IO-LINK MASTER PANEL (DIO, IO-LINK) IFM	17
AA060.000.14	ETHERNETIP IO-LINK MASTER PANEL (DIO, IO-LINK) IFM	17
AA060.101.01	IO-LINK TEMPERATURE TRANSMITTER PANEL IFM	17
AA060.101.02	CANOPEN RFID ANTENA PANEL IFM	17
AA060.101.03	IO-LINK RFID ANTENA PANEL IFM	17

AA061.001.03	PLC S7-314C TRAINING PANEL (CPU314C-2PN/DP)	10
AA061.001.04	PLC S7-317F SAFETY TRAINING PANEL (CPU317F-2PN/DP)	19
AA062.000.01	ET200SP (CPU 1512SP F) DIGITAL TRAINING PANEL	18
AA062.000.02	ET200SP (CPU 1512SP F) DISTRIBUTED TRAINING PANEL	18
AA062.000.03	ET200SP (CPU1512SP-F) SAFETY TRAINING PANEL	18
AA062.000.04	F-PLC TRAINING PANEL AND MOTOR CONTROL (CPU 1512SP)	18
AA062.001.01	ET200SP (CPU1512SP) DIGITAL TRAINING PANEL	9
AA062.001.02	ET200SP (CPU1512SP) DISTRIBUTED TRAINING PANEL	9
AA062.002.01	ET200SP (CPU1510SP) DIGITAL TRAINING PANEL	9
AA062.002.02	ET200SP (CPU1510SP) DISTRIBUTED TRAINING PANEL	9
AA062.003.01	ET200SP (CPU 1510SP F) DIGITAL TRAINING PANEL	18
AA062.003.02	ET200SP (CPU 1510SP F) DISTRIBUTED TRAINING PANEL	18
AA062.003.03	ET200SP (CPU 1510SP F) SAFETY TRAINING PANEL	18
AA062.003.04	F-PLC TRAINING PANEL AND MOTOR CONTROL (CPU 1510SP)	18
AA063.000.02	ET200SP (IM155-6PN) DIGITAL TRAINING PANEL	10
AA063.000.03	ET200SP (IM155-6PN) DIGITAL IO-LINK TRAINING PANEL	16
AA063.000.04	ET200SP (IM155-6PN) DIGITAL AS-I TRAINING PANEL	16
AA063.000.05	ET200SP (IM155-6PN) TRAINING PANEL	10
AA063.100.01	ET200S PN MOTOR STARTER TRAINING PANEL (PN COUPLER)	16
AA064.000.02	PLC NEXT TRAINING PANEL	11
AA066.001.01	PLC S7-1215C TRAINING PANEL (CPU1215C & KTP700)	9
AA066.001.02	PLC S7-1215C & HMI TRAINING PANEL (CPU1215C & KTP700)	9
AA066.001.03	PLC S7-1215C & HMI TRAINING PANEL (CPU1215C & TP700)	9
AA066.002.02	PLC S7-1215C TRAINING PANEL (CPU1215C-RLY & KTP700)	8
AA068.000.01	UPS PANEL PHOENIX CONTACT	21
AA071.000.03	HMI TP1500 COMFORT TRAINING PANEL	13
AA071.000.04	HMI MTP1500 UNIFIED TRAINING CASE	13
AA071.000.05	HMI MTP700 UNIFIED COMFORT TRAINING PANEL	13
AA071.000.06	HMI TP1200 COMFORT TRAINING PANEL	13
AA071.001.03	HMI TP1500 COMFORT TRAINING CASE WITH FLEXIBLE SUPPORT	13
AA071.001.04	HMI MTP1500 UNIFIED TRAINING CASE WITH FLEXIBLE SUPPORT	13
AA071.001.05	HMI MTP700 UNIFIED COMFORT CASE WITH FLEXIBLE SUPPORT	13
AA071.001.06	HMI TP1200 COMFORT TRAINING CASE WITH FLEXIBLE SUPPORT	13
AA071.002.05	HMI MTP700 UNIFIED COMFORT CASE FOR CPS	13
AA071.003.01	MTP700 HMI INTERFACE CASE	13
AA072.000.01	HMI T30 TRAINING PANEL	14
AA072.000.02	HMI T50 TRAINING PANEL	14
AA073.001.01	PLC S7-1215C CANOPEN TRAINING PANEL (CPU1215C)	15
AA073.001.02	PLC S7-1215C IO-LINK TRAINING PANEL (CPU1215C)	15
AA073.001.03	PLC COMMUNICATIONS TRAINING PANEL (S7-1200)	15
AA073.001.04	SIEMENS COMMUNICATIONS TRAINING PANEL (S7-1200)	16
AA073.100.01	IO-LINK MOTOR STARTER TRAINING PANEL (SIEMENS)	16
AA074.000.01	EDUKIT PA EXTENSION PANEL	29
AA074.000.02	PLC EXTENSION PANEL	10
AA074.100.01	I/O TRAINING PANEL	19
AA076.000.01	PLC S7-315F SAFETY TRAINING PANEL (CPU315F-2PN/DP)	19
AA077.000.01	ET200SP (CPU1512SP-F) SAFETY TRAINING SYSTEM	19
AA078.000.01	PLC S7-412 TRAINING PANEL (CPU412-2PN)	12
AA080.000.01	I/O SAFETY TRAINING PANEL	19
AA081.000.01	SAFETY TRAINING SYSTEM	19
AA081.000.04	SINAMICS G120 TRAINING SYSTEM (3xAC MOTOR, 0.37 kW & ENC)	23
AA081.001.02	SAFETY RELAY TRAINING PANEL	19
AA081.002.02	SAFETY RELAY OUTPUT EXTENSION	19
AA083.000.01	DRIVE POWER PANEL (DC VARIABLE VOLTAGE)	21
AA086.000.01	SINAMICS DCM TRAINING SYSTEM DC MOTOR & TACHOMETER	23
AA087.000.02	COUPLED TANK SYSTEM ASTANK-2+ (L, F, P, T)	30
AA087.010.03	PLC S7-1516 TRAINING PANEL ASTANK-2+	30
AA087.011.02	PLC S7-1215C TRAINING PANEL ASTANK-2+	30
AA088.000.02	SENTRON PAC4200 ENERGY MEASUREMENT TRAINING PANEL	20
AA088.000.03	SENTRON PAC5200 ENERGY MEASUREMENT TRAINING PANEL	20
AA088.100.01	SENTRON PAC3220 ENERGY MEASUREMENT TRAINING PANEL	20
AA089.001.01	ENERGY METER TRAINING CASE (CPU1215C & SM 1238 & HMI)	20
AA089.001.02	ENERGY METER TRAINING PANEL (CPU1215C)	20
AA089.002.02	ENERGY METER TRAINING PANEL (CPU 1510SP)	20
AA089.002.03	ENERGY METER TRAINING PANEL (CPU 1512SP)	20
AA089.010.01	ENERGY MANAGEMENT SYSTEM (1AC-SIEMENS)	20
AA089.030.01	ENERGY MANAGEMENT SYSTEM (3AC-SIEMENS)	20

AA089.100.02	SOCKETS PANEL	33
AA090.001.01	WAGO 750-8101 DAQ TRAINING PANEL ASTANK-2+	30
AA090.101.03	PLC WAGO TRAINING PANEL (CPU750-8101)	11
AA090.101.04	PLC WAGO TRAINING PANEL (CPU750-890)	11
AA092.001.01	INVERTED PENDULUM LINEAR SYSTEM WITH MATLAB SUPPORT	30
AA092.002.01	BALL AND BEAM SYSTEM WITH MATLAB SUPPORT	30
AA092.003.01	BALL BALANCING TABLE WITH MATLAB SUPPORT	30
AA092.004.01	1-DOF HELICOPTER WITH MATLAB SUPPORT	30
AA092.005.01	STEWART PLATFORM (PROGRAMMING IN MATLAB)	30
AA093.000.01	PLC CECC - LK COMM.TRAINING PANEL	16
AA094.000.01	SINAMICS S120 TRAINING PANEL (1AC, 230V, 0.4 kW)	25
AA094.001.01	TRAINING SYSTEM FOR SERVOMOTOR (1 AC S120, Servo 1FK7. 0.4 kW)	25
AA094.101.01	CONVEYOR TOOTHED BELT WITH SYNCHRONOUS SERVOMOTOR (S120)	26
AA094.101.04	CONVEYOR TOOTHED BELT WITH ASYNCHRONOUS 3xAC MOTOR	26
AA094.101.06	CONVEYOR TOOTHED BELT WITH SYNCHRONOUS SERVOMOTOR (V90)	26
AA094.101.08	CONVEYOR TOOTHED BELT WITH OTT BRUSH DC SERVO DRIVE CAN	26
AA094.101.14	CONVEYOR TOOTHED BELT WITH ASYNCHRONOUS 3xAC (3x230/400)	26
AA094.101.18	CONVEYOR TOOTHED BELT WITH SYNCHRONOUS SERVOMOTOR (INDRADRIVE)	26
AA094.101.19	CONVEYOR TOOTHED BELT WITH SYNCHRONOUS SERVO (S210-1FK2)	26
AA094.101.20	CONVEYOR TOOTHED BELT WITH SYNCHRONOUS SERVO (S200-1FL2)	26
AA095.000.01	COMPACT PNEUMATIC PALLET STORAGE UNIT	27
AA095.000.02	COMPACT PNEUMATIC BASE PIECE STORAGE UNIT	27
AA095.000.03	COMPACT PNEUMATIC TOP PIECE STORAGE UNIT	27
AA095.000.04	PRESS PIECES UNIT	27
AA095.000.05	COMPACT PNEUMATIC INDEX UNIT	27
AA095.000.06	COMPACT PNEUMATIC STORAGE UNIT	27
AA095.100.01	3D PRINTED PIECES (SET WITH TAG)	33
AA095.101.01	3D PRINTED PIECE (PALLET WITH TAG)	33
AA096.001.01	CPS ROBOT ASSEMBLY-DISASSEMBLY STATION (ABB IRB1100)	34
AA096.001.03	GRIPPER FOR TRAINING ROBOT	28
AA096.001.04	DOUBLE GRIPPER FOR TRAINING ROBOT	28
AA096.001.05	CAGE FOR TRAINING ROBOT	33
AA096.002.01	CPS ROBOT ASSEMBLY-DISASSEMBLY STATION (MITSUBISHI RV-2FR-D)	34
AA096.003.01	CPS ROBOT ASSEMBLY-DISASSEMBLY STATION (UNIVERSAL ROBOTS UR3E)	34
AA096.004.01	CPS ROBOT ASSEMBLY-DISASSEMBLY STATION (ABB CRB 1100)	34
AA097.003.01	CONVEYOR TECH FLAT BELT (120 mm) (CENTRAL DRIVE)	26
AA097.003.02	CONVEYOR TECH FLAT BELT (120 mm) (END DRIVE)	26
AA100.101.06	CYBER-PHYSICAL SYSTEM (TOOTHBELT/V90 SERVOMOTOR)	35
AA100.101.08	CYBER-PHYSICAL SYSTEM (TOOTHBELT/DC SERVOMOTOR)	35
AA100.101.14	CYBER-PHYSICAL SYSTEM (TOOTHBELT/AC MOTOR)	35
AA100.101.18	CYBER-PHYSICAL SYSTEM (TOOTHBELT/INDRADRIVE SERVOMOTOR)	35
AA100.101.19	CYBER-PHYSICAL SYSTEM (TOOTHBELT/S210 SERVOMOTOR)	35
AA100.101.20	CYBER-PHYSICAL SYSTEM (TOOTHBELT/S200 SERVOMOTOR)	35
AA200.000.02	COMPACT WORKSTATION WITH WHEELS & MODULAR SUPPLY PANEL	32
AA200.000.03	TABLE-TOP STAND SIZE (WxH) 910 x 800 mm	32
AA200.000.04	TABLE-TOP STAND WITH MODULAR SUPPLY PANEL (3AC) SIZE (WxH) 910 x 790 mm	32
AA200.000.05	TABLE-TOP STAND WITH MODULAR SUPPLY PANEL (1AC) SIZE (WxH) 910 x 790 mm	32
AA200.000.06	TABLE-TOP STAND WITH MODULAR SUPPLY PANEL (1AC) SIZE (WxH) 910 x 1100 mm	32
AA200.000.15	TABLE-TOP STAND WITH MODULAR SUPPLY PANEL (1AC 230V+PAC1600) (WxH) 910x790	32
AA200.001.01	WORKSTATION (2000 x 800 x750) WITH 1AC MODULAR SUPPLY PANEL	32
AA200.001.02	WORKSTATION FOR ROBOTCELL (ABB MITSUBISHI) WITH MODULAR SUPPLY PANEL	32
AA200.001.03	WORKSTATION FOR ROBOTCELL (UR3E CRB1100) WITH MODULAR SUPPLY PANEL	32
AA200.002.02	WORKSTATION FOR ADVANCED MECHATRONICS LAB	33
AA200.003.01	WORKSTATION (2000 x 800 x750) WITH 3AC MODULAR SUPPLY PANEL	32
AA203.000.01	TRAINING SYSTEM FOR RESIDENTIAL ELECTRICAL INSTALLATION	21
AA204.000.01	TRAINING SYSTEM FOR ELECTRICAL INSTALATIONS	21
AA205.000.03	TRAINING SYSTEM FOR AC MOTOR & ENCODER (3AC MOTOR, 0.37kW, DRIVE 1AC G120PN)	23
AA205.001.03	TRAINING SYSTEM FOR AC MOTOR & ENCODER (3AC MOTOR,0.37 kW, DRIVE 1AC G120PN)	23
AA205.002.03	TRAINING SYSTEM FOR AC MOTOR (3AC MOTOR,0.37 kW, DRIVE 1AC V20)	23
AA205.003.04	TRAINING SYSTEM FOR AC MOTOR (3AC MOTOR, 1.5 kW, DRIVE 1AC G120PN)	23
AA205.013.04	AC MOTOR G120 PN TRAINING SYSTEM (G120 3xAC/AC MOTOR 400/600, ENCODER)	23
AA402.000.01	SAFETY CONNECTION CABLES 4MM 0.5M	19
AA402.000.02	SAFETY CONNECTION CABLES 4MM 1M	19
AA402.000.03	I/O DATA CABLE WITH SYSLINK CONNECTORS	33
AA402.000.04	ANALOG CABLE PARALLEL	33
AA500.000.01	TRAINING CONTROL CABINET (LOGO! 0BA8)	21
AA500.001.02	TRAINING CONTROL CABINET (S7-1215C)	21

AA500.100.01	TRAINING CONTROL CABINET (LOGO! OBA8)	21
AA503.000.03	PLC S7-1516 TRAINING CASE (CPU1516-3PN)	7
AA503.000.04	PLC S7-1516F TRAINING CASE (CPU-1516F-3PN)	19
AA503.000.05	PLC S7-1512 TRAINING CASE (CPU1512-1PN)	7
AA503.000.06	PLC S7-1215C TRAINING CASE (CPU1215C)	9
AA503.000.07	PLC S7-1513 TRAINING CASE (CPU-1513-1PN)	7
AA503.001.01	ET200SP (IM155-6PN) TRAINING CASE	10
AA503.002.01	PLC S7-1215C & HMI TRAINING CASE (CPU 1215C & KTP700)	9
AA503.002.02	PLC S7-1215C & HMI COMMUNICATION TRAINING CASE (KTP700)	15
AA503.002.03	PLC S7-1516 &HMI TRAINING CASE (CPU-1516-3PN/DP & MTP700)	7
AA503.002.04	PLC S7-1516F & HMI TRAINING CASE (CPU-1516F-3PN/DP & MTP700)	18
AA503.002.05	PLC S7-1512 &HMI TRAINING CASE (CPU 1512C-1PN & MTP700)	7
AA503.002.07	PLC S7-1513 &HMI TRAINING CASE (CPU1513-1PN & MTP700)	7
AA504.000.02	PLC & HMI COMMUNICATION TRAINING CASE (CX9020 & CP6606)	15
AA504.001.01	BECKHOFF PLC & HMI TRAINING CASE (CX9020 & CP6606)	10
AA505.000.01	ALLEN BRADLEY TRAINING CASE (CLOGIX 5370 + PANELVIEW 800 GRAPHIC)	11
AA505.001.01	ALLEN BRADLEY TRAINING CASE (CLOGIX 1769 + PANELVIEW 800 GRAPHIC)	11
AA506.000.01	MAGNETIC HYSTERESIS CYCLE MEAS.(B/H) EQUIPMENT	29
AA600.101.04	PROSIM V+ SMART DIGITAL PROCESSES	31
AA600.102.01	PROSIM V+ 10.5 INCH TABLET DISPLAY	31
AA600.103.01	PROSIM V+ ALL IN ONE PC 23.8" I5 TOUCH	31
AA700.001.02	ADVANCED SMART FLEXIBLE ASSEMBLY TRAINING SYSTEM (ABB IRB120 ROBOT)	36
AA700.002.02	ADVANCED SMART FLEXIBLE ASSEMBLY TRAINING SYSTEM (MITSUBISHI RV-2FR ROBOT)	36
AA700.003.02	ADVANCED SMART FLEXIBLE ASSEMBLY TRAINING SYSTEM (UNIVERSAL ROBOTS UR3e)	36
AA700.004.02	ADVANCED- SMART FLEXIBLE ASSEMBLY TRAINING SYSTEM (ABB CRB 1100)	36
AA700.101.02	SMART CYBER-PHYSICAL SYSTEM ASSEMBLY LINE (AXIS) (UR3E ROBOT)	37
AA700.111.16	INDUSTRY 4.0 ADVANCED TRAINER CYBER-PHYSICAL SYSTEM (ABB IRB1100)	38
AA700.112.16	INDUSTRY 4.0 ADVANCED TRAINER CYBER-PHYSICAL SYSTEM (MITS RV-2FR)	38
AA700.113.16	INDUSTRY 4.0 ADVANCED TRAINER CYBER-PHYSICAL SYSTEM (UR3E)	38
AA700.114.16	INDUSTRY 4.0 ADVANCED TRAINER CYBER-PHYSICAL SYSTEM (CRB1100)	38
AA701.101.02	MES SOFTWARE PACKAGE FOR SMART CPS ASSEMBLY LINE (WITH UR3)	39
AA701.110.16	MES SOFTWARE PACKAGE FOR ADVANCED TRAINER CPS (V90/1FL6)	39
AA800.001.01	SMART SENSORS & COMMUNICATIONS TRAINING SYSTEM (IFM)	40
AA800.002.01	INDUSTRIAL DETECTION OBJECTS SENSORS TRAINING SET (IFM)	41
AA800.002.02	INDUSTRIAL SMART SENSORS TRAINING SET (IFM)	41
AA900.010.01	SMART PROCESS CONTROL LEARNING SYSTEM (WATER TANK)	42
AA900.010.03	SMART PROCESS CONTROL LEARNING SYSTEM (1x AIR FAN)	44
AA900.010.05	SMART PROCESS SYSTEM WITH HMI CONTROLLER (2xAIR FANS)	45
AA900.010.13	DIGITAL CONTROLLER (1xAIR FAN)	44
AA900.010.15	HMI PROGRAMABLE CONTROLLER (2xAIR FANS)	45
AA900.020.01	SMART PLC PROGRAMMING LEARNING SYSTEM (PLC S7-1212C)	46
AA900.020.02	SMART PLC PROGRAMMING LEARNING SYSTEM (PLC S7-1214C)	46
AA900.020.03	SMART PLC PROGRAMMING LEARNING SYSTEM (PLC S7-1215C)	46
AA900.020.12	SMART PLC PROGRAMMING LEARNING SYSTEM (PLC S7-1511C)	47
AA900.020.13	SMART PLC PROGRAMMING LEARNING SYSTEM (PLC S7-1513)	47
AA900.020.16	SMART PLC PROGRAMMING LEARNING SYSTEM (PLC S7-1516)	47
AA900.020.17	SMART PLC PROGRAMMING LEARNING SYSTEM (PLC S7-1516F)	47
AA900.023.14	SMART PLC PROGRAMMING LEARNING SYSTEM (PLC S7-314C)	48
AA900.025.10	SMART PLC PROGRAMMING LEARNING SYSTEM (PLC 1510SP)	48
AA900.025.12	SMART PLC PROGRAMMING LEARNING SYSTEM (PLC 1512SP)	48
AA900.030.01	SMART VIBRATION ANALYSIS LEARNING SYSTEM (IFM VSE 150)	49
AA900.030.02	ADVANCED SMART VIBRATION ANALYSIS LEARNING SYSTEM (SIEMENS S7-1200 SM 1238)	49
AA900.040.02	ADVANCED SMART MOTION CONTROL LEARNING SYSTEM	50
AA900.050.01	SMART ENERGY MANAGEMENT LEARNING SYSTEM	51
AA900.050.02	ADVANCED SMART ENERGY MANAGEMENT LEARNING SYSTEM	52
AA900.050.03	ADVANCED SMART ENERGY MANAGEMENT SYSTEM (CPU 1510SP)	53
AA900.060.01	INTELLIGENT ROBOTS AND MECHATRONICS LAB	54
AA900.060.03	INTELLIGENT MOBILE ROBOT PLATFORM	55
AA900.060.04	INTELLIGENT 4 WHEELS MOBILE PLATFORM	56
AA900.060.05	ADVANCED MECHATRONICS RESEARCH LAB	57
AA900.070.01	SMART 3 AXIS CARTESIAN ROBOT STATION (3x AXIS FESTO, 3x SERVO V90, CPUS7-1215C)	58
AA900.070.02	ADVANCED 3 AXIS CARTESIAN ROBOT STATION (3x AXIS FESTO, 3x SERVO V90, CPU1511T)	58
AA900.070.03	ADVANCED MECHATRONICS TRAINING SYSTEM (BOSCH REXROTH SICK)	59
AA900.080.01	INDUSTRIAL COMMUNICATIONS TRAINING SYSTEM (SIEMENS)	60
AA900.080.02	INDUSTRIAL COMMUNICATIONS TRAINING SYSTEM (BECKHOFF)	61
Case Alum-1	ALUMINIUM Case (Internal size (WxHxD): 505x455x115)	33
Case HPRC-1	CASE HPRC-1 CUBED FOAM (INT. SIZE: 749X525X366 mm)	33



ASTI Automation S.R.L.
139 Calea Plevnei
060011 Bucharest
Romania
Tel: +40 722 291 815
+40 723 425 323
Email: office@astiautomation.com
www.astiautomation.com

